

HAMPLUS

MBD-8G

Antenna Switch Controller

Operation Manual



V. 1.1



<http://www.hamplus.com>

MBD-8G

Automatic Antenna Switch Controller



MBD-8G is an intelligent controller compatible with all eight-antenna switches manufactured by Hamplus. It has a band decoder to receive the information coming from the connected radio equipment. In addition to antenna switching, the **MBD-8G** also offers seven frequency-driven **GPOs** (General Purpose Output), one **Band Data BCD Output**, one output to command **Band Pass Filter**, **12 GPOs** to automate the operation with Top Beam's Waller Flag receiving antenna. The **MBD-8G** also commands the **RS-24** and **RS-44** Rotator switches. There are four ways that antennas and enabled rotators can be selected; 1) manually by the front panel of the **MBD-8G**, 2) manually by frequency or band change on the front panel of the transceiver, 3) automatically by frequency or band change by the remotely controlled transceiver, or 4) automatically by a remotely controlled personal computer via **RS-232** serial port to the **MBD-8G**.

On the front panel is a set of eight illuminated push buttons for manual selection of antennas, eight "Busy" LEDs to indicate which antennas are in use by other **MBD-8G** Controllers, four LEDs to indicate rotator selection, one LED to indicate when the radio is transmitting, one LED to indicate the controller is in "Split Antenna" mode and one LED to indicate when the **MBD-8G** is connected to +13.8 Vdc power.

Functions and operation

1- Startup (after all cable connections are made to switches, controllers and transceivers)

Powering the **MBD-8G** will energize the antenna switch relay for the previously, manually selected antenna. Or, when connected to a transceiver, the controller will check the frequency or band the transceiver has selected and will immediately trigger and light the push button switch of the last antenna selected at that frequency or on that band. If connected, the rotator switcher, or other external equipment that is programmed using the **GPO** outputs, the **MBD-8G** will select the last used devices.

2- Activation of the antennas

To choose any antenna, just press the corresponding push button. When the push button is pressed, it changes the state of the antenna switch control line that activates the corresponding antenna relay on the **AS-81**, **AS-82F**, **AS-84F** or **AS-86F** Antenna Switch. It also activates the selected rotator for that antenna through one of the Rotator Switches, model **RS-24** or **RS-28**, if used. Antenna and rotator switching are reported on the Busy Net network so the other **MBD-8G** busy and rotator red LEDs signal, not allowing any other **MBD-8G** to switch to any antenna and rotator already in use. Any conflict is signaled on the front panel of the **MBD-8G** by blinking the push button LED for two seconds, and the rotator LED with short and continuous flashes every second. The rotator signal remains as long as there is a conflict.

3- Split Antenna Mode

This mode allows operation with two different antennas. One for transmission and one for reception.

Procedure to enter SPLIT mode:

A- First select the transmission antenna.

B- Then press and hold the PTT of the radio and press the desired antenna push button for reception for two seconds. The push button will blink to confirm that the setting has been made. Then release the push button and the PTT. From this point the Split LED on the panel will be lit indicating that it is working with two antennas.

Immediately after programming the Split mode, perform the function test by pressing and releasing the PTT of the radio and observing the push buttons of the **MBD-8G** that should alternate between the chosen antennas.

To exit Split mode simply change the radio band or press the transmit antenna push button.

4- Permanent Split Mode

Permanent Split is used with antenna(s) connected to the switch that are exclusively for reception. When we select an antenna configured for permanent Split on the keyboard of the **MBD-8G** the Split mode is automatically activated. This way we guarantee the use of the receiving antenna only in reception. This procedure must be duplicated on all controllers connected to the same antenna switch that has receive only antenna(s) connected.

Procedure to configure Permanent Split mode:

A- First choose a transmission antenna.

B- Then press and hold the PTT of the radio and press the desired antenna push button for reception for a little more than ten seconds. Notice the flashing of the push buttons that will confirm the acceptance of the programming.

To undo this setting, first make sure that the Split LED is not lit. Then, while holding down the PTT, press the desired push button for ten seconds. It is the same process used when programming was done.

5- Rotor Switch

The **MBD-8G** can also command a Hamplus model **RS-24**, or **RS-44** rotator switch. With this equipment it is possible to use one rotator controller to read and control up to 4 rotators. The **RS-24** is suitable for stations with up to two transceivers and **RS-44** for stations with up to four transceivers.

Procedure to configure the Rotator Switch

- 1- **First step-** Press the antenna button that will receive the configuration for five seconds. At this moment the buttons Ant1, Ant2, Ant3 and Ant8 start to flash.
- 2- **Second step-** Press the **Ant1 Button** to enter the **Rotor selection mode**
- 3- **Third step-** Press the **Ant1 button** to choose **Rotor 1**, **Ant2 Button** to choose **Rotor 2**, **Ant3 Button** to choose **Rotor 3** or **Ant4 Button** to choose **Rotor 4**
- 4- **Fourth step-** Press **Ant8 button** to save your choice and exit the mode configuration.

6- **CMD Out (#7) (GPO = General Purpose Output)**

These commands are available on the DB-9 **Com Out** connector at the rear of the **MBD-8G**.

a- **Commands activated by frequency**

Frequency-activated **GPOs** are typically used to trigger the tuning box for shortened antennas that use "high Q" coils. The trigger points of the **GPOs** must be chosen to obtain the best possible **SWR** curve. This procedure is only possible when the radio is connected to the **MBD-8G** in CI-V mode (Icom) or in RS-232 mode for other brands.

Procedure to configure the GPOs by frequency:

- 1- **First step**- Press the antenna button that will receive the configuration for five seconds. At this moment the buttons Ant1, Ant2, Ant3 and Ant8 start to flash.
- 2- **Second step**- Press the **Ant2 Button** to enter frequency-activated GPOs (CMD Out)
- 3- **Third step**- Start at the beginning of the band and find the best tuning point, then press the **Ant1** Button to activate **CMD1**. Raise the frequency on the radio and find the next tuning point then press the **Ant2** button to activate the **CMD2**. Repeat this procedure for the next available tuning points on your antenna. The **MBD-8G** has a maximum of seven **CMDs**.
- 4- **Fourth step**- Press **Ant8 button** to save your choice and exit the mode configuration.

b- **Commands Activated by Band**

The band activated commands (**GPOs**) were created to reduce the influence of the transmission antennas on the receiving antennas when they are very close.

Its function is to disconnect the transmitting antenna during reception and connect it as soon as it receives the **Send** command.

Procedure to configure GPOs by band:

- 1- **First step**- Press the antenna button that will receive the configuration for five seconds. At this moment the buttons Ant1, Ant2, Ant3 and Ant8 start to flash.
- 2- **Second step**- Press the **Ant3 Button** to enter band-activated GPOs (CMD Out)
- 3- **Third step**- Place the radio in the desired band and choose a GPO that is not yet in use, then press the **Ant** Button to activate **CMD**. The **MBD-8G** has seven **GPOs** commands that are chosen from the buttons **Ant1** to **Ant7**.
Each **Band** triggers only one **GPO**.
- 4- **Fourth step**- Press **Ant8 button** to save your choice and exit the mode configuration.

7- **Communication with Icom, Yaesu, Kenwood, Elecraft K-3, Flex Radio via RS-232 and BCD**

To use the MBD-8G's automation functions, it must communicate with the radio. For ICOM brand radios, we use the CI-V protocol (MBD-8G CI-V port). With this protocol all the features described above will be able to work. For the equipment of the YAESU brand we use the band data information, which allows all configurations except the activation of the GPOs by frequency. For those of the brand Kenwood, Flex Radio and Elecraft K3 the protocol used is by the RS-232 communication port that allows use of all functions of the MBD-8G.

Protocol and Baud rate

- Icom radios CI-V Baud rate 19,200
- Yaesu radios Band Data BCD
- Kenwood, Elecraft, Flex radio, RS-232 Baud rate 9,600

Elecraft K3 can use Band Data or RS-232 with Kenwood protocol

8- Band Data Table

BCD Band Data

<u>Band</u>	<u>Frequency</u>			<u>BCD</u>
160 m	0.0	to	2.9 MHz	0001
80 m	3.0	to	4.8 MHz	0010
60 m	4.9	to	5.9 MHz	0000
40 m	6.0	to	8.9 MHz	0011
30 m	9.0	to	12.9MHz	0100
20 m	13.0	to	16.9 MHz	0101
17 m	17.0	to	18.9 MHz	0110
15 m	19.0	to	22.9 MHz	0111
12 m	23.0	to	25.9MHz	1000
10 m	26.0	to	34.9 MHz	1001
6 m	35.0	to	54.9 MHz	1010

Frequency Band for communication via RS-232 and CI-V

Band 1 from 0 to 400KHz, **Band 2** from 400KHz to 540KHz, **Band 3** from 540KHz to 1.6 MHz, **Band 4** from 1.6 to 1.8 MHz, **Band 5** from 1.8 to 2.0 MHz, **Band 6** from 2.0 to 3.5 MHz, **Band 7** From 3.5 to 4.0 MHz, **Band 8** from 4.0 to 5.4 MHz, **Band 9** from 5.4 to 7.0 MHz, **Band 10** from 7.0 to 7.3 MHz, **Band 11** from 7.3 to 8.0 MHz, **Band 12** from 8.0 to 11.0 MHz, **Band 13** from 11.0 MHz to 15.0 MHz, **Band 14** from 15.0 MHz to 20.0 MHz, **Band 15** from 20.0 MHz to 22.0 MHz, **Band 16** from 22.0 MHz to 25.0 MHz, **Band 17** from 25.0 MHz to 28.0 MHz, **Band 18** from 28.0 MHz to 30.0 MHz, **Band 19** from 30.0 MHz to 60.0 MHz, **Band 20** from 60.0 MHz to 143.5.0 MHz, **Band 21** from 143.5 MHz to 144.4 MHz, **Band 22** from 144.4 MHz to 148.0 MHz, **Band 23** from 148.0 MHz to 225.0 MHz, **Band 24** from 225.0 MHz to 430.0 MHz, **Band 25** from 430.0 MHz to 450.0 MHz, **Band 26** Above 450 MHz

9- Antenna memory per band

The **MBD-8G** has a memory for each of the eight antennas so that whenever an antenna is selected this memory registers the band selected by the Radio. With each band change in the radio the **MBD-8G** will activate the last antenna that was used in that band.

Note: The setting mode is only possible when the Radio is properly connected to the **MBD-8G**.

10- Connectors description (connector # on rear panel image)

a- Band Data Out (#3)

The DB-9 **Band Data Out** connector on the rear of the **MBD-8G** provides a Band Data output that matches the frequency of the radio that is connected. When the **MBD-8G** receives the band information from the Band Data, this same information will be passed to the Band Data Out connector. When receiving the information through Frequency the conversion to Band Data will be done according to the table in item 8.

DB-9 Band Data Out connector

Pins	Function
1	Band Data A
2	Band Data B
3	Band Data C
4	Band Data D
5	+ 13.8 Vdc
6	nc
7	nc
8	GND
9	nc

b- Bandpasser Out (#2)

The DB-9 **To Bandpasser** connector on the rear of the **MBD-8G** is designed to control bandpass filters. It sends + 13.8 Vdc to the bandpass filter relays. They are commands for 160m, 80m, 40m, 20m, 15m, 10m.

DB-9 To Bandpasser connector

Pins	Band	Frequency	Function
1	20 m	13.0 to 16.9 MHz	On +13.8Vdc
2	40 m	6.0 to 8.9 MHz	On +13.8Vdc
3	80 m	3.0 to 4.8 MHz	On +13.8Vdc
4	160 m	0.0 to 2.9 MHz	On +13.8Vdc
5	-----	-----	GND
6	-----	-----	
7	-----	-----	Bypass On +13.8Vdc
8	10 m	26.0 to 34.9 MHz	On +13.8Vdc
9	15 m	19.0 to 22.9 MHz	On +13.8Vdc

All control pins are Active High + 13.8 Vdc

c- TOPBEAM Waller Flag (#5)

The **HD-15** connector labeled **TB WF** on the rear of the **MBD-8G** provides power (+ 13.8 Vdc) and the controls for activating the filters of the **Waller Flag** receiving antenna control box. The commands follow the Band data table or the Radio frequency.

HD-15 TB WF connector

Pins	Band	Frequency	Data	Function
1	160 m	0.0 to 2.9 MHz	0001	On Active Low
2	80 m CW	3.4 to 3.59MHz	0010	On Active Low
3	80 m SSB	3.6 to 4.8 MHz	0010	On Active Low
4	40 m	6.0 to 8.9 MHz	0011	On Active Low
5	30 m	9.0 to 12.9MHz	0100	On Active Low
6 and 7	-----	-----	-----	+ 13.8vdc
8	-----	-----	-----	PTT
9 and 10	-----	-----	-----	GND
11	-----	-----	-----	RTX On Active Low
12	-----	-----	-----	RX1 On Active Low
13	-----	-----	-----	RX2 On Active Low
14	-----	-----	-----	RX3 On Active Low
15	-----	-----	-----	RX4 On Active Low

d- DB-9 To Radio Connector (#8)

This connector receives power from the Radio (+ 13.8 Vdc), the transmit command (PTT) and the data for frequency reading via RS-232 and Band reading via Band Data BCD.

DB-9 To Radio Connector

<u>Pins</u>	<u>Function</u>
1	+13.8V In
2	RXD
3	TXD
4	PTT In
5	GND
6	BCD 1
7	BCD 2
8	BCD 3
9	BCD 4

e- DB-25 To Switch Connector (#1)

DB-25 connector on the rear of the **MBD-8G** provides the commands for driving eight Antennas and four Rotators

DB-25 To Switch Connector

<u>Pins</u>	<u>Function</u>	<u>Pins</u>	<u>Function</u>	<u>Pins</u>	<u>Function</u>
1	Ant 1	10	GND	18	Rotator 1
2	Ant 2	11	nc	19	Rotator 2
3	Ant 3	12	nc	20	Rotator 3
4	Ant 4	13	Expansion	21	Rotator 4
5	Ant 5	14	Rotator 1	22	nc
6	Ant 6	15	Rotator 2	23	nc
7	Ant 7	16	Rotator 3	24	nc
8	Ant 8	17	Rotator 4	25	GND
9	+ 12v				

f- DB-9 RS-232 connector (#9)

The DB-9 connector identified as **RS-232** on the back of the **MBD-8G** provides connection to Computers at a speed of **19200 baud**.

DB-9 RS-232 connector

<u>Pins</u>	<u>Function</u>
1	NC
2	RXD
3	TXD
4	NC
5	GND
6	NC
7	NC
8	NC
9	NC

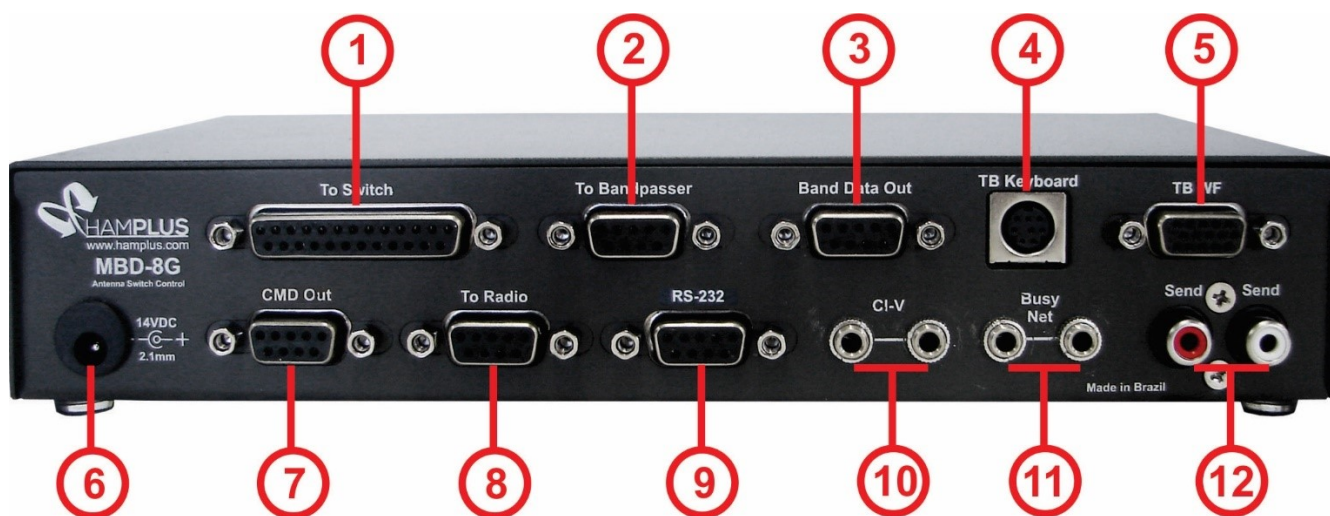

- | | |
|----------------------|---|
| 1- To Switch | Output Commands to Antenna Switch and Rotator Switch |
| 2- To Bandpasser | Output Commands for Bandpass Filter |
| 3- Band Data Out | Band Data Output (BCD) |
| 4- TB Key Board | Output for Key Board Antenna TopBeam Receiver Waller Flag |
| 5- TB WF | Connects to the PFIU of the receiving antenna TopBeam Waller Flag |
| 6- AUX. Power Supply | Auxiliary Power Input (13.8 Vdc) |
| 7-CMD Out | GPOs Out (special commands triggered by frequency or band) |
| 8- To Radio | Input Power, Band Data, RS-232 and PTT from Radio |
| 9- RS-232 | Communication with PC Com port |
| 10- CI-V | Communication with Icom radios via CI-V port |
| 11- Busy Net | Busy Network for indication of antennas in use |
| 12- Send | Auxiliary input and pass-through output for PTT (Send) |

Connection diagram for two Icom Radios, eight Antennas Switch and four Rotator Switch

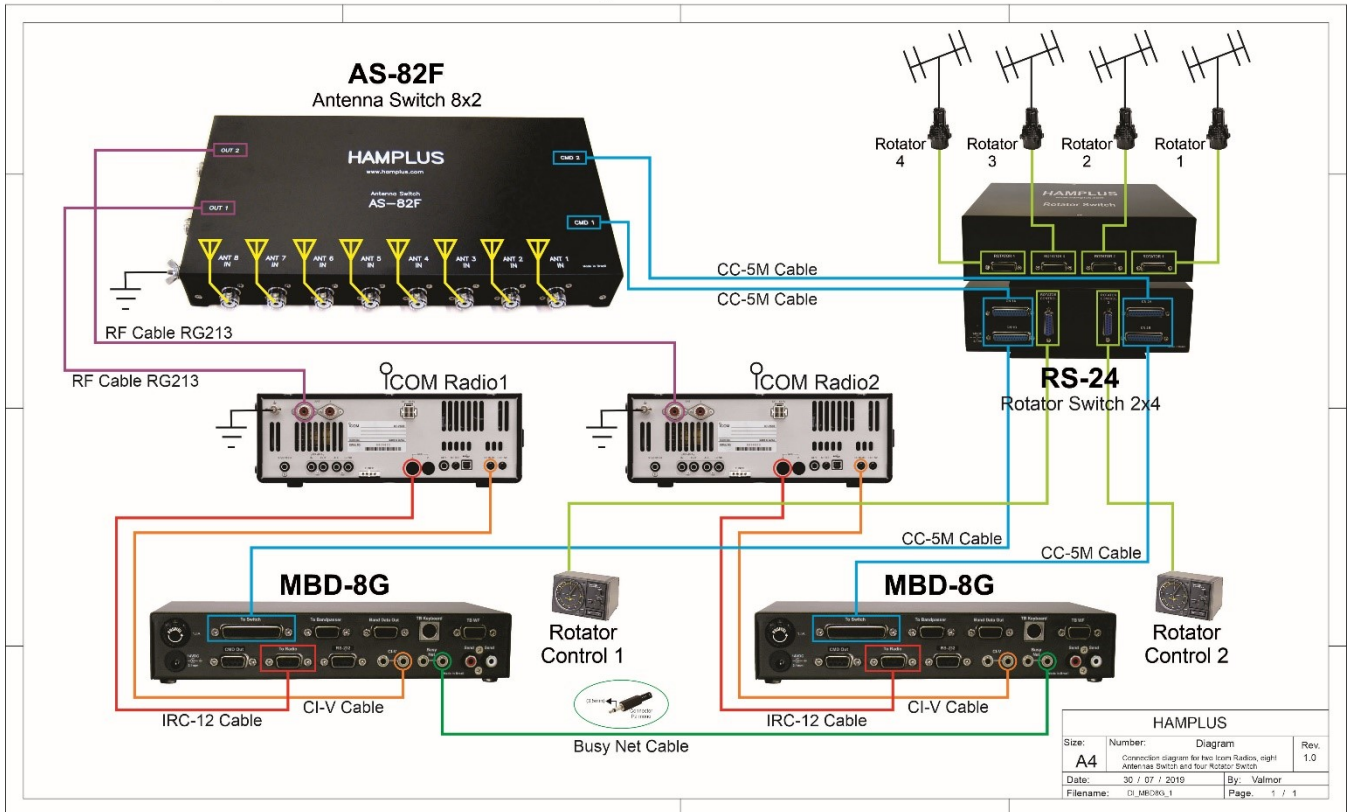

Connection diagram for one Icom Radio, sixteen Antennas Switch and eight Rotator Switch

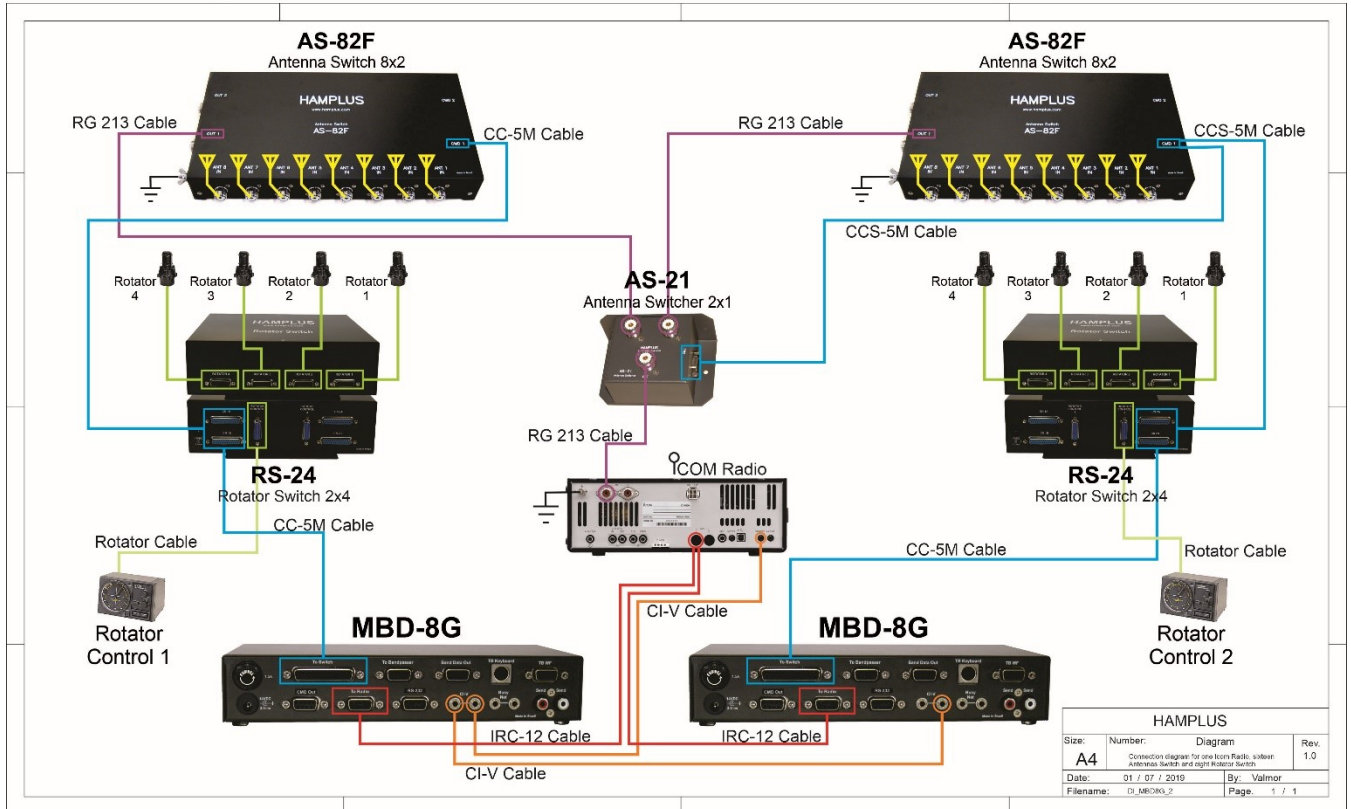

Connection diagram of the Hamplus MBD-8G with Bandpass Filter - Model - DXE-419.

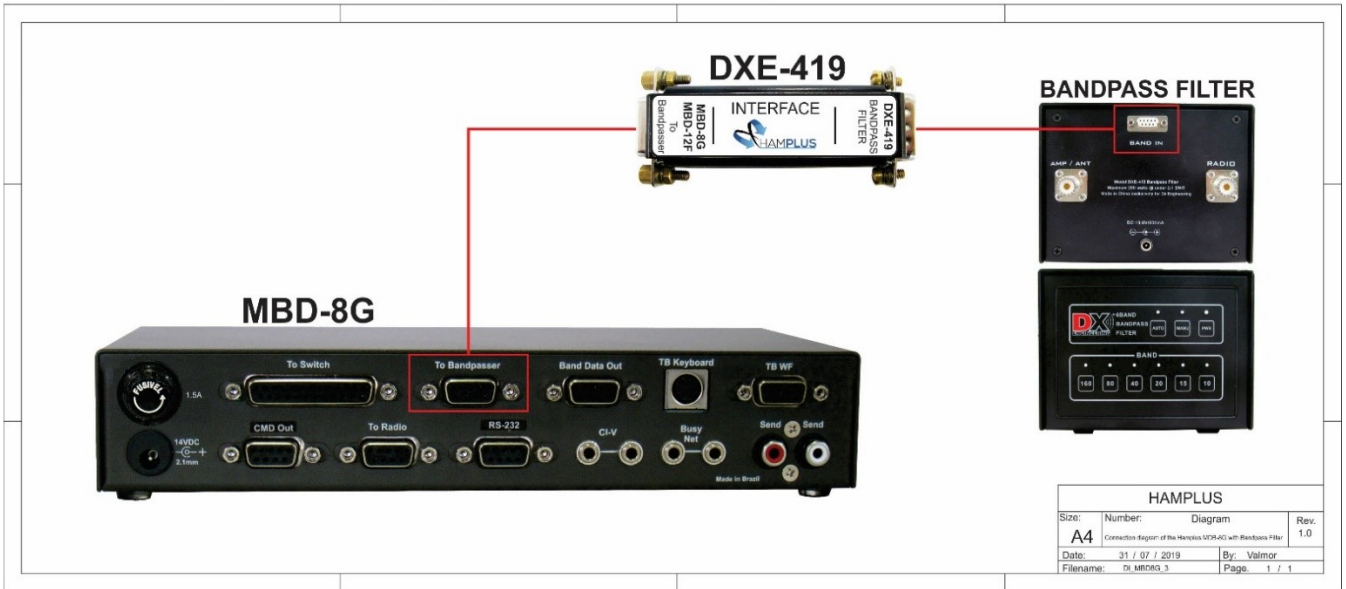
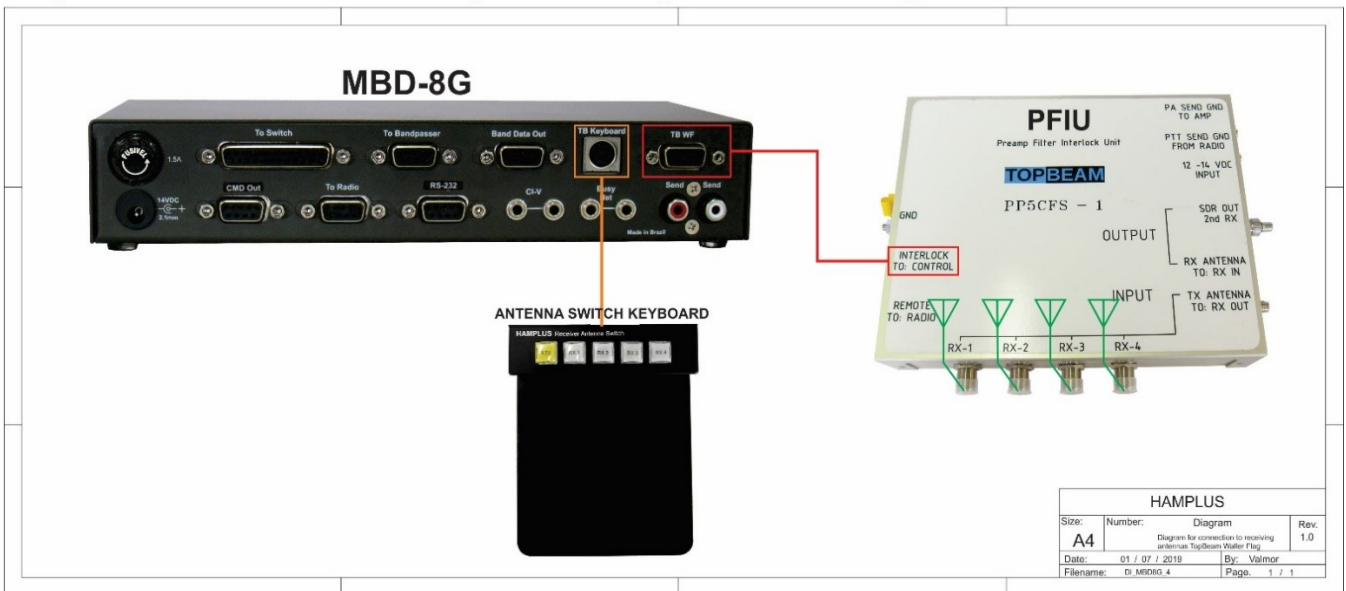

Diagram for connection to receiving antennas TopBeam Waller Flag



Labels - print on transparent paper with laser printer

160 m	80 m	40 m	20 m	18 m	17 m	15 m	12 m	10 m	6 m	2 m
70 cm	80 m 40 m	20 m 15 m 10 m	MULTI BAND	LOG						

Procedure to place labels on the keys

Push Button Labels



1

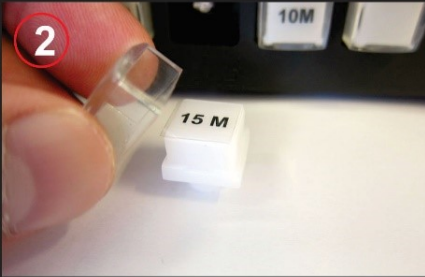

2

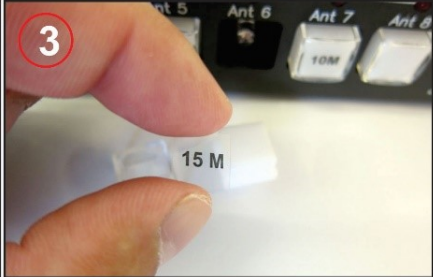

3

HAMPLUS		
Size:	Number:	Rev.
A4	Push Button Labels	1.0
Date:	By:	Valmor
Filename: Labels	Page:	1 / 1

MBD-8G CONNECTOR PIN IDENTIFICATION



MBD-8G

To Switch

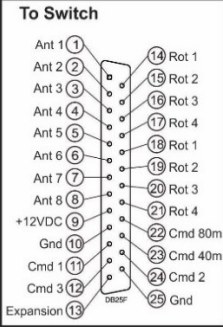

TB WF

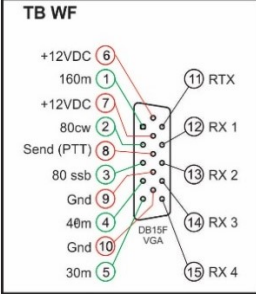

To Bandpasser

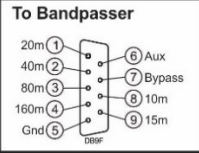

Band Data Out

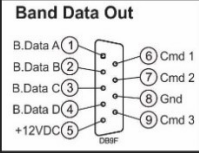

TB Key Board

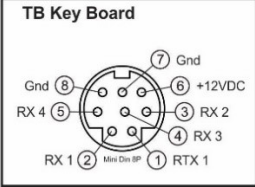

CMD Out

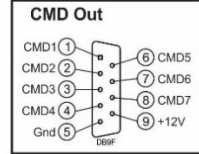

To Radio

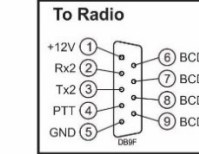

RS 232

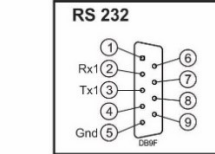

HAMPLUS		
Size:	Number:	Connector Pin Identification
A4	MBD-8G	Rev. 1.0
Date:	By:	Valmor
Filename: PLMBD8G	Page:	1 / 1

MBD-8G – Operation Manual

Page 12

CC-5M CABLE - CONNECTOR PIN IDENTIFICATION

CC-5M

Other models:

- CC-7M
- CC-10M
- CC-15M
- CC-20M
- CC-30M

HAMPLUS			
Size: A4	Number: CC-5M CABLE	Connector Pin Identification	Rev: 1.1
Date: 15 / 12 / 2020	By: Valmor		
Filename: CE-CC-5M	Page: 1 / 1		

MBD-8G / AS-81S Connection Cable

MBD-8G

MBD-8G To Switch DB-25M	Connection Cable	AS-81S CMD
1	ANT 1	1
2	ANT 2	2
3	ANT 3	3
4	ANT 4	4
5	ANT 5	5
6	ANT 6	6
7	ANT 7	7
8	ANT 8	8
9	+13.8V	9/10
10	GND	11/12

AS-81S

HAMPLUS			
Size: A4	Number: MBD-8G-AS-81S	Connection Cable	Rev: 1.0
Date: 02 / 08 / 2019	By: Valmor		
Filename: CE-MBD-8G-AS-81S	Page: 1 / 1		

MBD-8G / AS-82F Connection Cable

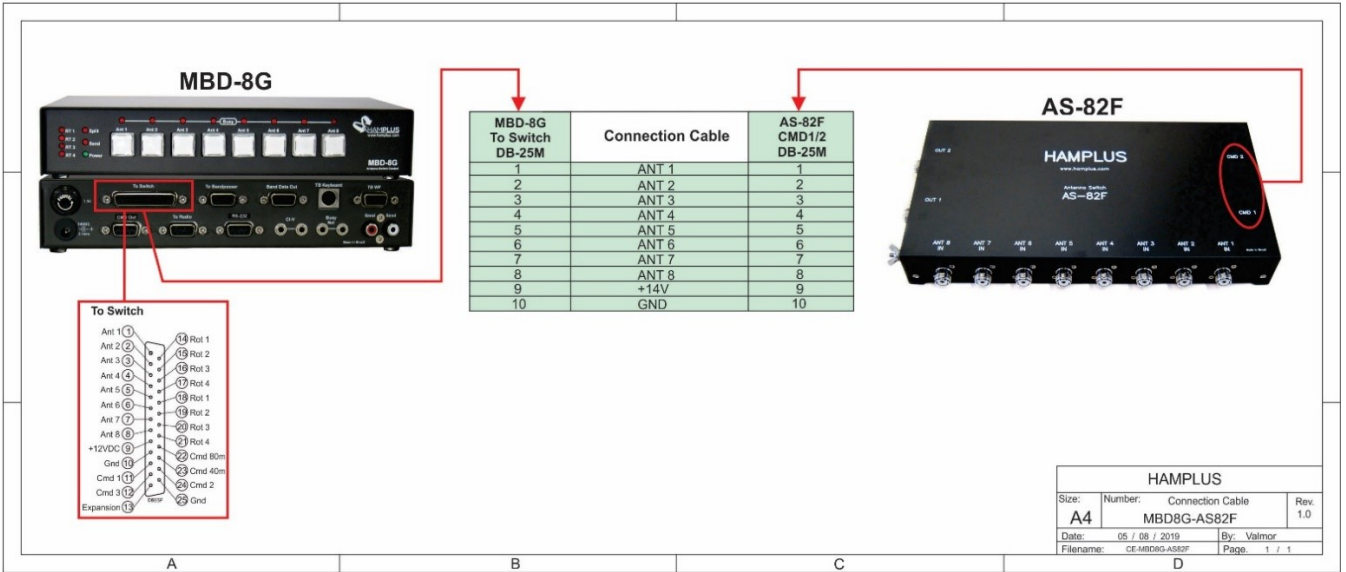

MBD-8G / ICOM Connection Cable

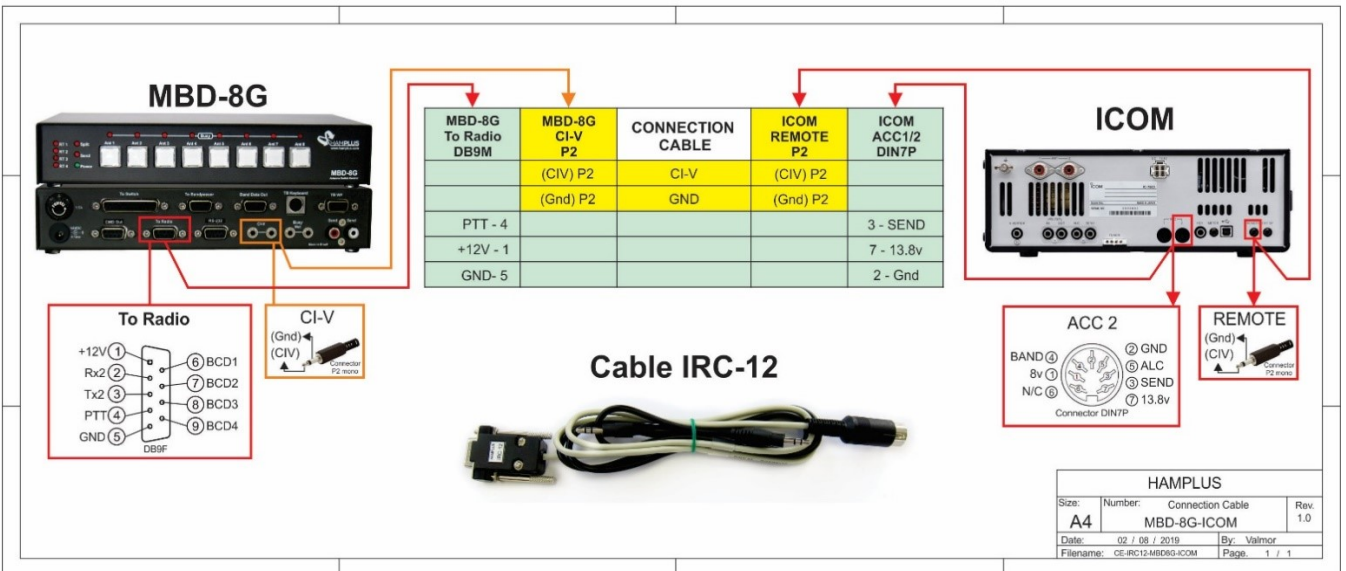

MBD-8G / ICOM Connection Cable

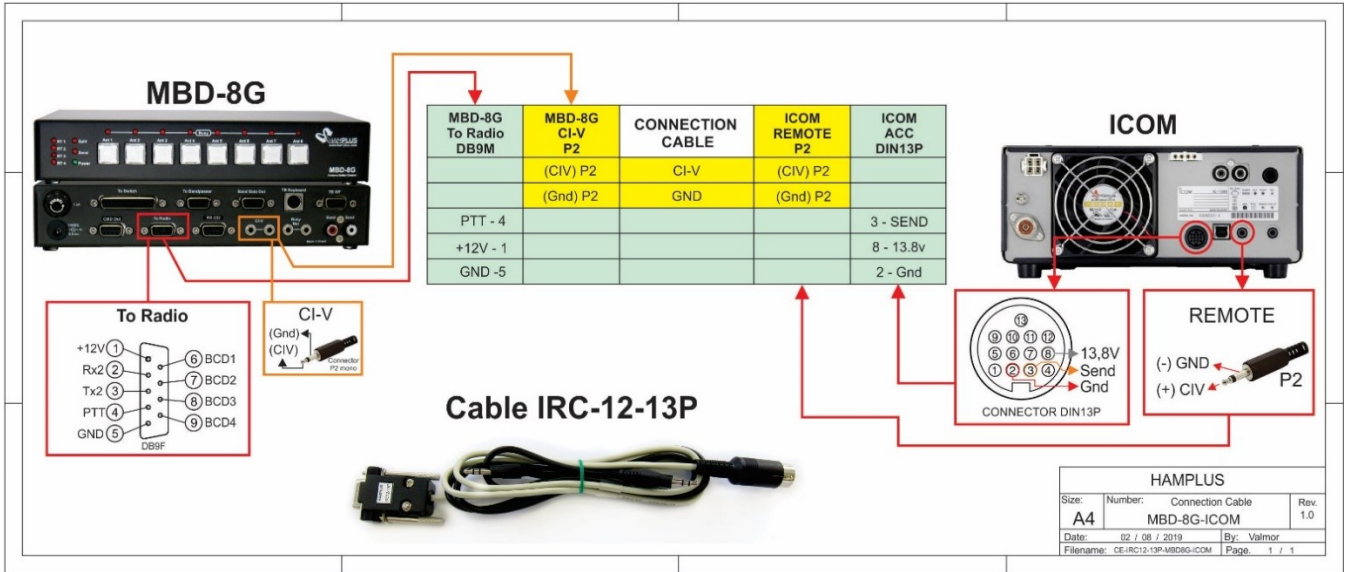

MBD-8G / ICOM Connection Cable

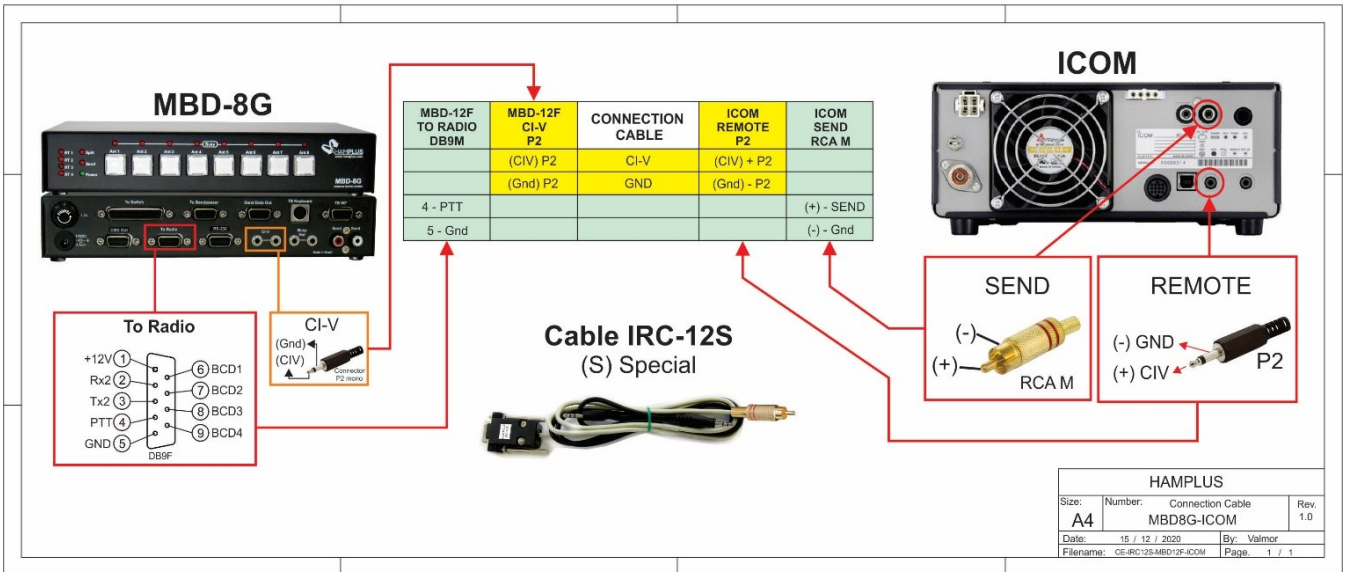

YRC-12-8P Cable

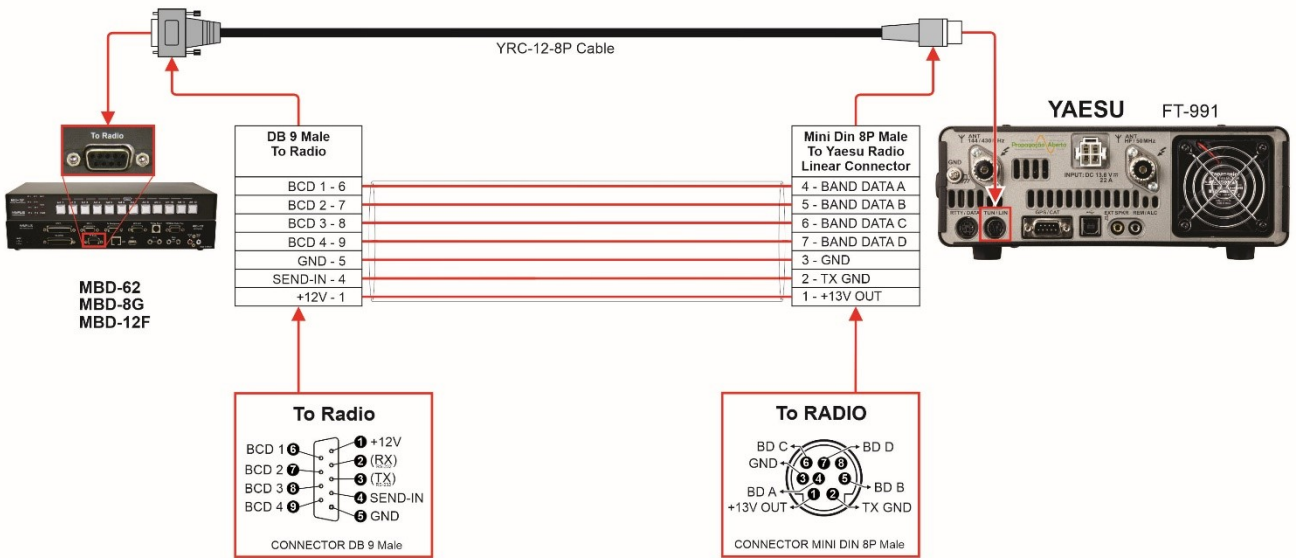

Applicable for Yaesu radios with Band Data connector compatible with models:

FT-991



Date: 30 / 11 / 2021	By: Valmor
Filename: CE-YRC-128P	Rev.: 1.0

YRC-12-8P8 Cable

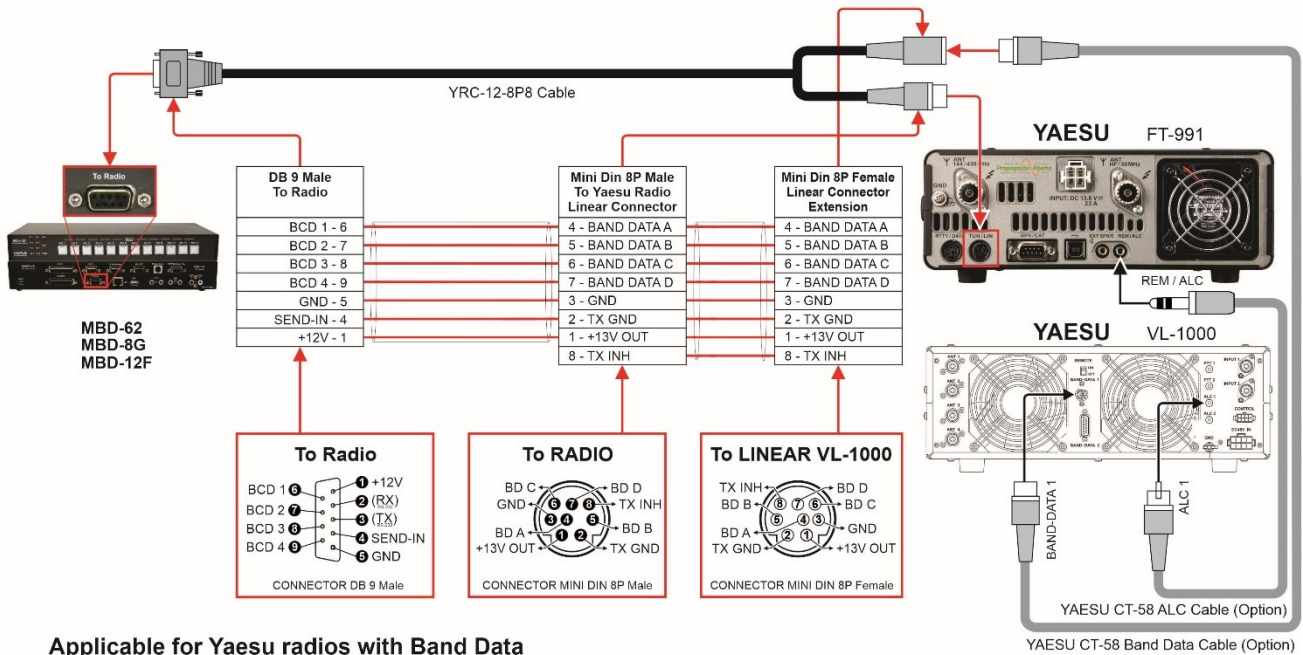

Applicable for Yaesu radios with Band Data connector compatible with models:

FT-991



Date: 30 / 11 / 2021	By: Valmor
Filename: CE-YRC-128P8	Rev.: 1.0

YRC-12-10P Cable

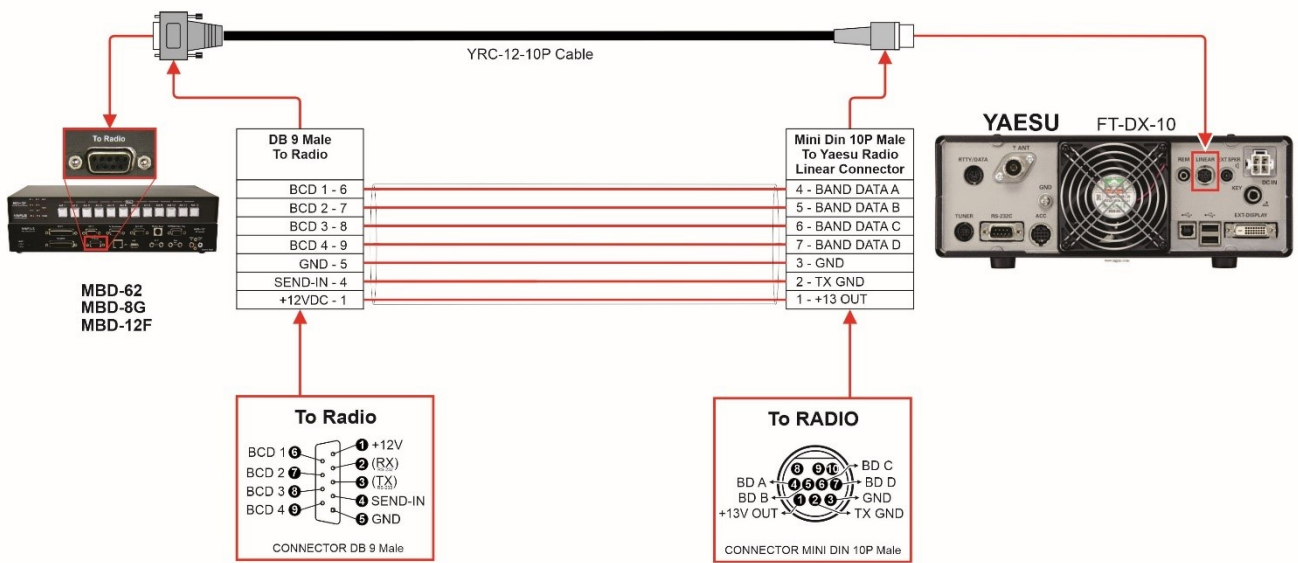

Applicable for Yaesu radios with Band Data connector compatible with models:

FT-DX10
FT-DX1200
FT-450D



Date: 07 / 12 / 2021	By: Valmor
Filename: CE-YRC-12-10P	Rev.: 1.0

YRC-12-15P Cable

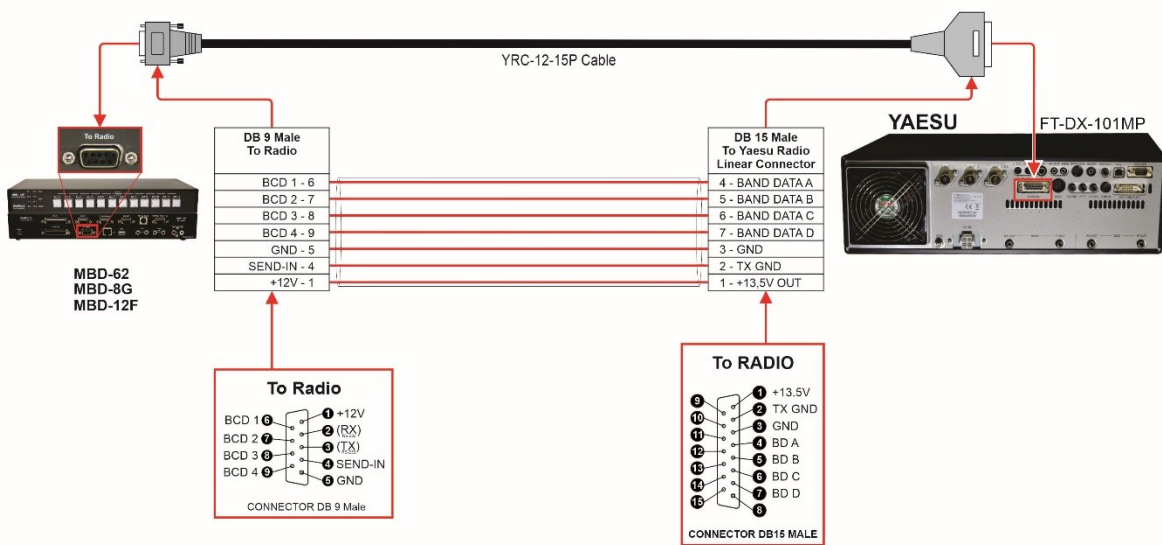

Applicable for Yaesu radios with Band Data connector compatible with models:

FT-DX101MP
 FT-DX101D
 FT-DX3000



Date: 07 / 12 / 2021	By: Valmor
Filename: CE-YRC-12-15P	Rev.: 1.0

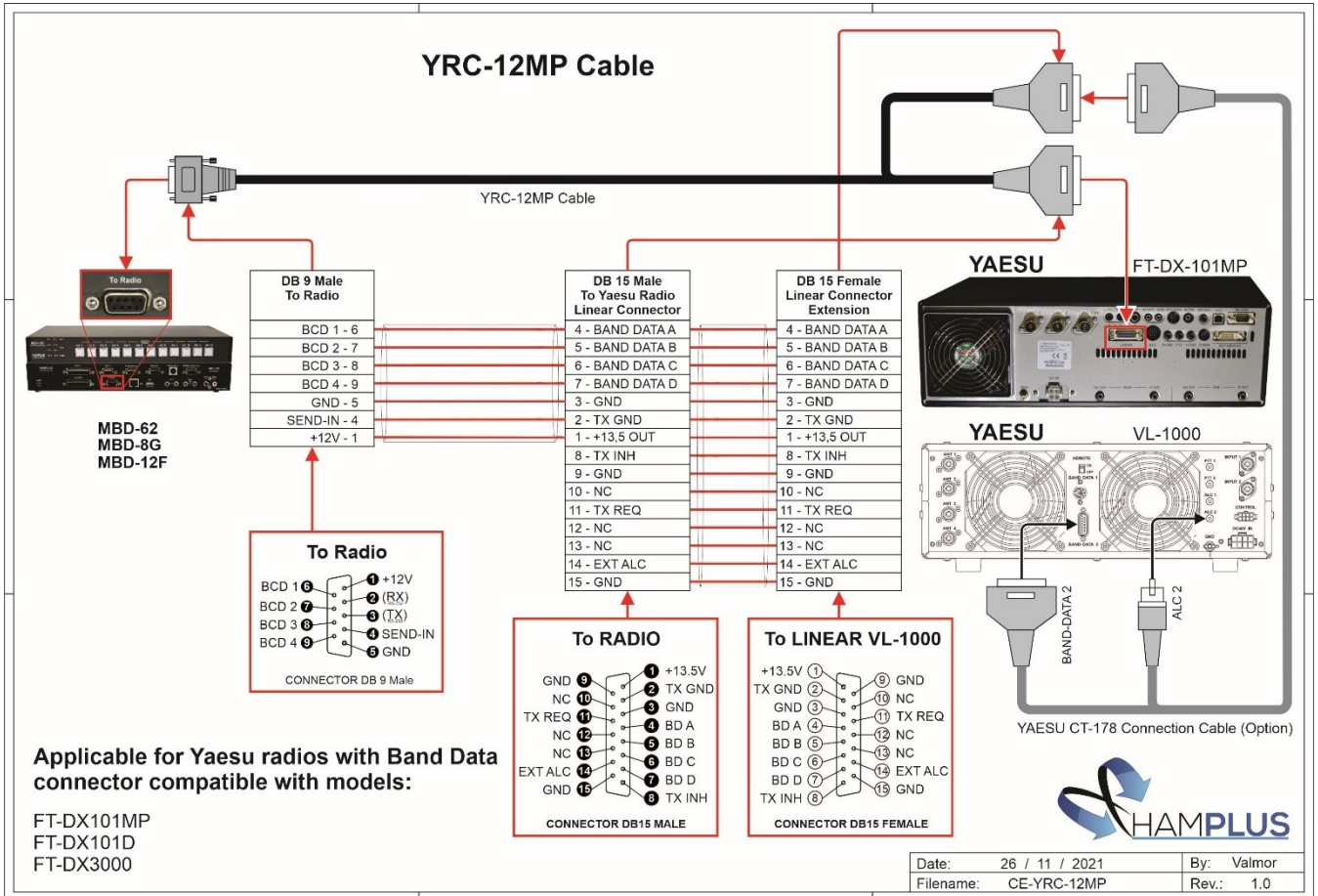

MBD-8G / KENWOOD Connection Cable

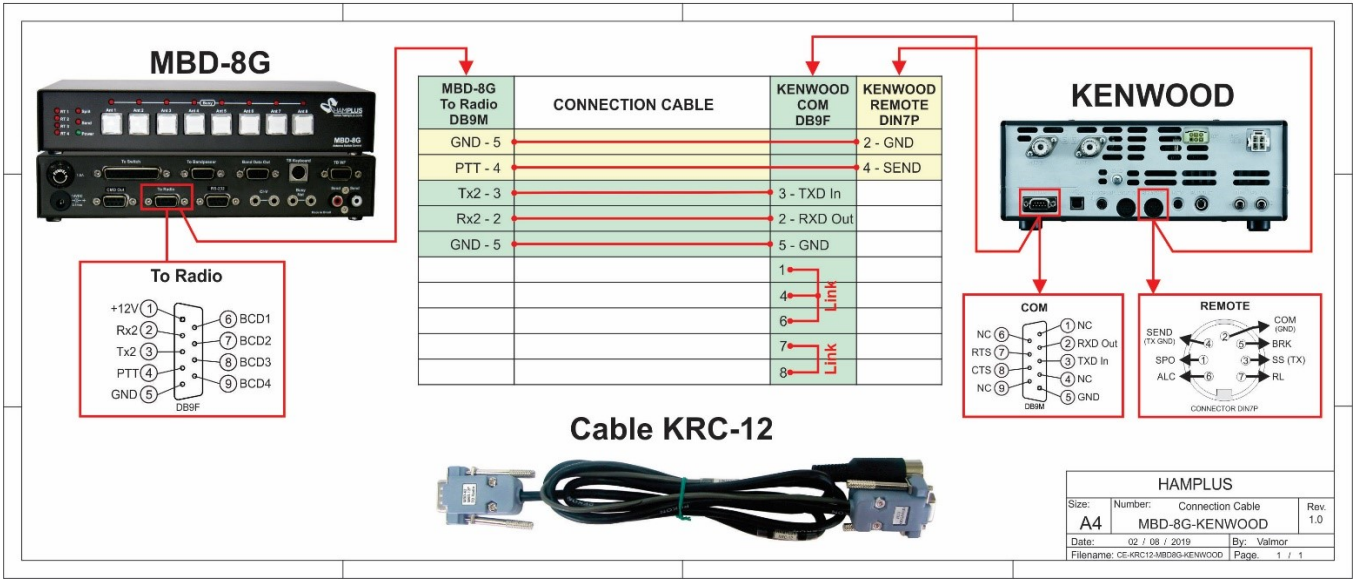

MBD-8G / YAESU Connection Cable

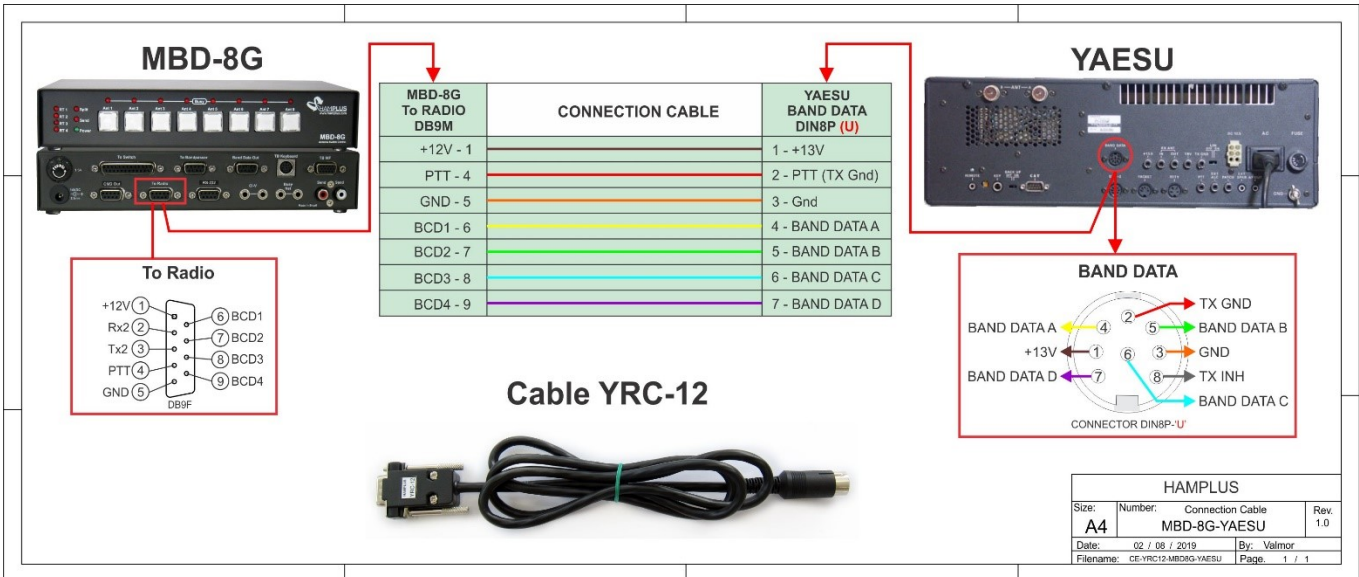

MBD-8G / ELEKRAFT K3 - Connection Cable

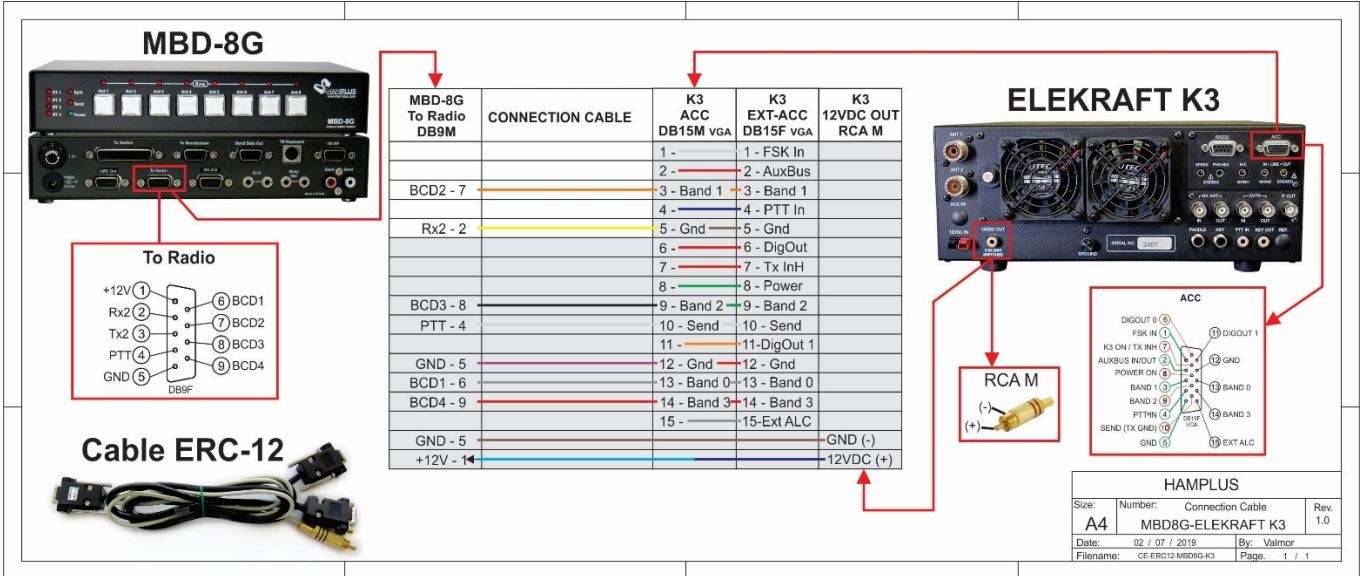

MBD-8G / FLEX Connection Cable

