

AS-603UR

Operation Manual

AS-61VR / RC-603VR/RPS-1 Set
6x3 Automatic Wireless Antenna Switch with Rotator Controller
Commands over RF Cable

Operation from 1.8 MHz to 450 MHz

AS-603UR Operation Manual



V. 1.1

AS-603UR

AS-61VR / RC-603VR/RPS-1 Set

6x3 Automatic Wireless Antenna Switch with Rotor Controller

The **AS-61VR / RC-603VR / RPS-1** set is an automatic antenna switch for three Radios, six Antennas and control for two **Rotators**. There are three independent boxes, the **AS-61VR** for changing antennas, which is close to antennas, and the **RC-603VR** with the Push Buttons for the selection of the antennas and Radios, and the control of the **Rotators** with a three-digit Display, an Encoder and two LEDs, which is close to the Radios. The third box, **RPS-1**, is for driving the two **Rotors**. The **RPS-1** receives the activation commands from the **AS-61VR** and the power from an external 110/220 VAC source. **The connection between the AS-61VR and the RC-603VR is made only by the RF cable (RG-58 or RG-213). This cable takes RF and the necessary commands for the perfect operation of this system.** The operation is individual, this means that only the selected radio will have access to the Antennas and Rotators. Unused antennas are automatically shorted.

To facilitate the operation, the **RC-603VR** has an internal switch that switches the **Send** command and the **Com** port to the selected Radio.

The **AS-603UR** supports communication with the following radios:

Icom (CI-V), **Kenwood** (RS-232), **Elecraft K3** (RS-232), **Yaesu** (RS-232), **Flex Radio** (RS-232) or any other Radio that uses one of these communication protocols.

Procedure for connecting the RC-603VR to the radio:

- 1- On the **RC-603VR** press and hold the yellow radio select Push button and turn on the **RC-603VR**.
- 2- Then press the Antenna Push Button corresponds to the model of the radio that you will connect, according to the list below;
 - a- **Ant 1** Push Button for **Icom** (CI-V) radios **Baud rate 19200**
 - b- **Ant 2** Push Button for **Yaesu** type FT-817, FT-857 and others. **Baud rate 4800**
 - c- **Ant 3** Push Button for **Yaesu** type FT-1000 MP radios and others. **Baud rate 4800**
 - d- **Ant 4** Push Button for **Yaesu** type FT-5000 radios and others. **Baud rate 4800**
 - e- **Ant 5** Push Button for **Kenwood, Elecraft, Flex Radio**, and others. **Baud rate 4800**

After the choice, the **Split/Data LED** stops blinking, this indicates the end of this procedure.

Procedure to activate Split mode:

To activate **Split** mode, the **RC-603VR** must be connected to the radio with the appropriate cable and **the TX Delay of the radio must be set to 20 ms or more.**

- 1- Press the **PTT** on the radio and watch the **RC-603VR's Send LED** light up.
- 2- Then, with the **PTT** still pressed, press and release the button of the antenna that you want to receive.
- 3- When **PTT** is released, the **RC-603VR** will switch to the chosen receiving antenna.

Each time you press the PTT, it returns to the transmitting antenna.

Any change of antenna or band on the radio deactivates Split mode.

Testing and using the automatic antenna selection feature of the RC-603VR/AS-61VR with a connected and selected radio:

NOTE: No computer programming, PC connection or internal changes are required. A connected radio means that it is interfaced to the RC-603VR with a cable, such as Hamplus ERC-6, IRC-6, KRC-6, YRC-6, FRC-6 or YRC-61, and the radio set to the correct baud rate (19,200 baud CI-V or 4800 baud CAT and COM) and set up as described in the previous section.

If the RC-603VR is not interfaced as described, then it may be operated as a Manual Antenna Switch.

When connected, the RC-603VR is an Automatic Band Memory Antenna Switch that may be operated manually. "Programming" automatic antenna selections are made as each different band is selected on the connected and selected radio. The initial manual selection of a specific antenna for that band is made by depressing the desired Ant button, which is then automatically memorized. There is no "SAVE" button nor is there a multi-button programming sequence. Just set the antenna by the band on the radio.

Restated, simply assign or reassign any RC-603VR Ant button number to any band by initial or subsequent manual selection. For every and any band chosen and displayed on the connected and selected radio, every time a different antenna button is manually depressed, that selection is memorized.

Here is an example of antenna memorization by band setting on the transceiver connected to and selected as **Radio 1** on the **RC-603VR**:

1. Select 40 meters on Radio 1 and press **Ant 2** on the **RC-603VR** (as if your 40 meters antenna is connected to the **Ant 2** port on the **AS-61VR**)
2. Select 80 meters on Radio 1 and press **Ant 1** on the **RC-603VR** (as if your 80 meters antenna is connected to the **Ant 1** port on the **AS-61VR**)
3. Select 20 meters on Radio 1 and press **Ant 3** on the **RC-603VR** (as if your 20 meters antenna is connected to the **Ant 3** port on the **AS-61VR**), and so on.

Now, test the automation by changing back to the 40 meters band on your radio. The **RC-603VR** should now automatically switch to **Ant 2**.

Then, select 80 meters on your radio and the **RC-603VR** automatically switches to **Ant 1**, and so on.

If automatic antenna selection by band or frequency does not occur, then reattempt the **Procedure for connecting the RC-603VR to the radio** in the section above.

Supporting the use of a multi-band antenna, the **RC-603VR** provides the ability to assign any single antenna port to any number of bands on the connected radio, also by initial manual selection.

For example: A 20/15/10 meters tri-band beam coaxial cable is connected to **Ant 3** port on the **AS-61VR**.

4. Select 20 meters on the connected radio and press **Ant 3** on the **RC-603VR** (because your tri-band antenna is connected to **Ant 3** port on the **AS-61VR**)
5. Select 15 meters on the connected radio and press **Ant 3** on the **RC-603VR** (because your tri-band antenna is connected to **Ant 3** port on the **AS-61VR**)
6. Select 10 meters on the connected radio and press **Ant 3** on the **RC-603VR** (because your tri-band antenna is connected to **Ant 3** port on the **AS-61VR**)

Now, test the tri-bander automation by selecting any of those bands, 20, 15 and 10 meters, on your radio. The **RC-603VR** will now automatically stay on **Ant 3**, or go back to **Ant 3** after selecting a band with a different band memorized.

7. Select 80 meters on your radio and the **RC-603VR** automatically switches to **Ant 1**,
8. Then, select 20 meters on your radio and the **RC-603VR** automatically switches back to **Ant 3**... and so on.

IMPORTANT FEATURE: PC interface to this antenna switch controller is not necessary. Interfaced transceivers that are also controlled locally or remotely by USB or LAN will continue to benefit from this Automatic Band Memory Antenna Switch. This smart controller method of automatic antenna selection is simply made by band or frequency selection with the radio control program.

REMINDER: Reassignment of any band or frequency to a different antenna port is simply made by manual reselection of the new antenna port number whenever the connected radio is set on that specific band or frequency. The manual change is automatically updated by the **RC-603VR** for only the selected radio. Simply stated, reassign any Ant # to any band by manual reselection of the new Ant # whenever the radio is set to that band.

For example, let's say that you now want to move your 40 meters antenna to the **Ant 5** port on the **AS-61VR**. Simply select 40 meters on the connected radio and press **Ant 5** on the **RC-603VR**, and it memorizes this change. Each time you change this radio to a 40 meters frequency, **Ant 5** will now be automatically selected.

NOTE: On any given radio band, any manual antenna selection that is made, even if it happens to be incorrect, will be memorized. So, check and recheck each of your band memorized antenna selections by changing to each of the bands on your connected and selected radio and watching the **RC-603VR** automatically change to the correct antenna. Correct any wrong Ant # on any band by manual selection.

Rotor Operation:

Introduction:

The **RC-603VR**'s Rotator Controller consists of a three-digit Display to indicate the azimuth of the antenna in use, an Encoder to choose the new azimuth and two LEDs to indicate the Rotator that is in use.

Each of the six antennas can be associated with either or both Rotators. This way, when an antenna is selected, the **Rotator** associated with it is also selected and its azimuth is indicated on the Display. When you want to change the azimuth of the antenna you just need to turn the Encoder until you see the new azimuth on the Display. The Display also shows the movement of the antenna until it reaches the new chosen azimuth.

Initial settings:

The first task to be done is to calibrate the **Rotator**. It aims to synchronize the position of the **Rotator** with the indication of the Display.

1- Rotator calibration:

Calibration is a simple task that must be done before placing the Rotator on the tower. Before starting the calibration, connect all cables between the parts involved. Start by connecting the **Rotators** to the **RPS-1**, this one to the **AS-61VR**, and this through an **RF** cable to the **RC-603VR** control. Also connect the **RPS-1** to the power source.

- a- **First step-** Switch on the **RC-603VR** with the Encoder button pressed. Wait with the Encoder pressed until the Display shows **0 0 0** then release the Encoder. At this point, the Display will show **C A L** indicating that you are in the **Rotator** calibration mode. The Display will be showing **C A L** throughout the calibration procedure.
- b- **Second step-** *Choose which **Rotator** to be calibrated.* For **Rotator 1**, turn the Encoder counterclockwise (**ccw**) until the **Rotator 1** indicator **LED** lights up. For **Rotator 2**, turn the encoder clockwise (**cw**) until the **Rotator 2** indicator **LED** lights up.
- c- **Third step-** *Position the rotator at the starting point of the stroke.* Press the Encoder momentarily. At this point, the **Rotator** will begin to rotate until it finds the starting point of the rotator stroke. Then he stops the **Rotator** and turns on the **Ant4** button and **Ant6** button.
- d- **Fourth step-** *Position the **Rotator** at the end of the stroke.* Now you must create a reference point for this **Rotator** position, with the greatest possible precision, so you will rotate the **Rotator** clockwise (**cw**) in one complete revolution (360 degrees) using the **Ant6 (cw)** button and **Ant4 (ccw)** button until it reaches exactly the point where the **Rotator** started the turn. This is the end point of the **Rotator** stroke.

- e- **Fifth step-** *Finish the calibration.* After the start and end of the stroke are marked, momentarily press the Encoder. The Display stops showing **C A L** and starts showing the **Rotator** position, (**1 8 0**). **Rotator** calibration is complete.
- f- **Sixth step-** *Install the **Rotator** on the tower.* Now with the **Rotator** calibrated you can place it on the tower.

2- **Antenna alignment:**

After calibrating the **Rotator**, you can place it on the tower and install the antenna.

Suggestion for antenna alignment:

Adjust the **Rotator** position to the **North**, placing **0 0 0** degrees on the Display. Then place the Antenna towards the **North** and fix it on the **Rotator**. Do not forget the magnetic declination, as the Antenna must be pointed towards the **true North**. So, the display indication will always be the correct direction of the Antenna.

3- **Choice of Rotator for the antenna:**

The **RC-603VR** can control up to two **Rotators**. This procedure is for associating an antenna to a **Rotator**. So, when you select the antenna the controller will be connected to the **Rotator** of this antenna, the **LED** indicator of the **Rotator** in use will be illuminated and the Display will indicate the position of the antenna.

- a- **First step-** *Enter the **Rotator** choice mode.* Press the **Ant** button for five seconds. At this moment the **Ant6** button starts to flash and the **Ant1** and **Ant2** buttons are available to choose **Rotator1** or **Rotator2** respectively.
- b- **Second step-** *To choose the **Rotator**.* For **Rotator 1** press the **Ant1** button, for **Rotator 2** press the **Ant2** button. When the button is pressed it is illuminated and **LED RT1** or **LED RT2** is also illuminated, indicating the chosen **Rotator**. The **RT1** and **RT2 LEDs off** indicate that the Antenna is not connected to any **Rotator** and the Display indicates **O F F**.
- c- **Third step-** *Save and exit.* To save and exit, press the flashing **Ant6** button.

4- **Start and end of course, North or South:**

The **RC-603VR**'s **Rotator** controller has the default to indicate the beginning and end of the **Rotator** stroke at **1 8 0** degrees, which represents the **South** position.

This position can be switched to indicate **0 0 0** degrees, which represents the **North** position.

To change the indication

- a- **First step-** Press the Encoder for five seconds. At this moment the buttons **Ant1**, **Ant2**, **Ant3**, **Ant5** and **Ant6** start to flash.
- b- **Second step-** To change the indication, press the **Ant5** button.
*To abort the procedure, press the **Ant6** button.*

Important: If the antenna is already installed you will have to make a new alignment because the new indication on the Display will be **180 degrees** out of step with the old one.

5- Rotator stroke limit:

In some installations, such as on the side of a tower, the antenna cannot rotate 360 degrees because it encounters obstacles. For these cases, the **RC-603VR Rotator** controller has the Stroke Limit function.

Counterclockwise limit (CCW)

- a- **First step-** Position the antenna at the limit of the counterclockwise (**CCW**) direction. Do not let the antenna touch the obstacle, leave a small gap.
- b- **Second step-** *Save the counterclockwise limit point (ccw)*. After performing the first step Press the Encoder for five seconds. At this moment the buttons **Ant1**, **Ant2**, Ant3, Ant5 and **Ant6** start to flash. Press the **Ant1** button to save the limit counterclockwise (**ccw**) or press the **Ant6** button to abort this procedure.

To clear the limits, press the **Ant2** button.

Clockwise Limit (CW)

- a- **First step-** Position the antenna at the clockwise limit (**CW**). Do not let the antenna touch the obstacle, leave a small gap.
- b- **Second step-** *Save the clockwise limit point (cw)*. After performing the first step, press the Encoder for five seconds. At this moment the buttons Ant1, **Ant2**, **Ant3**, Ant5 and **Ant6** start to flash. Press the **Ant3** button to save the limit clockwise (**cw**), or press the **Ant6** button to abort this procedure.

To clear the limits, press the **Ant2** button.

Applicable rotor types:

The **Rotators** that can be used with this controller are those with a **24 VDC** motor and the direction indicator is a **500 Homs one-turn potentiometer**, or a **10K Homs 10-turn potentiometer**. Like Yaesu G800, G1000, G2800, Special Engine, Prosistel and others.

-----x-----

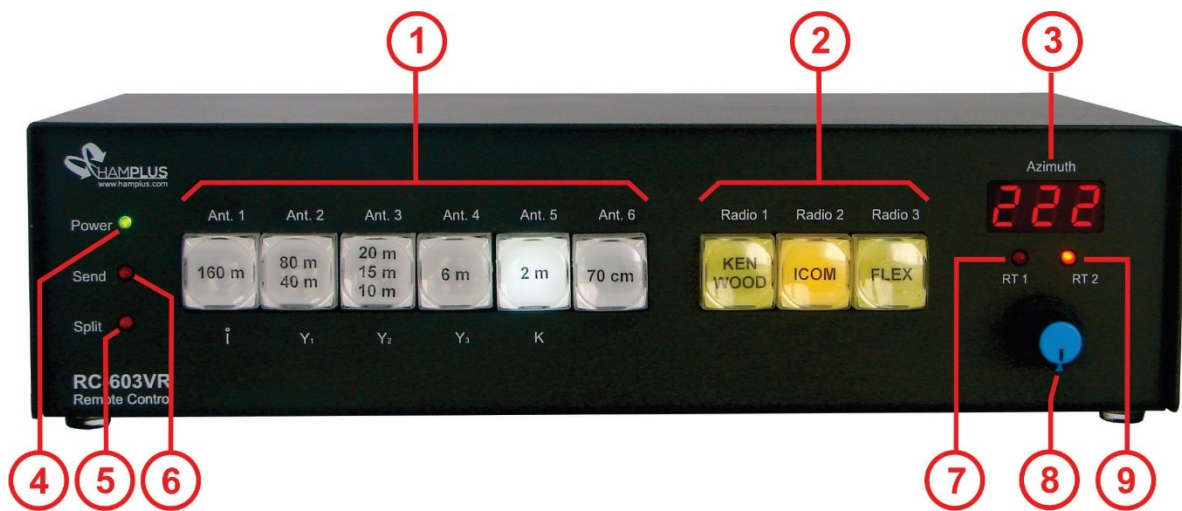

- 1- Antenna selection buttons
- 2- Radio selection buttons
- 3- Azimuth indicator display
- 4- Power On LED indicator
- 5- Split Antenna LED indicator
- 6- Send indicator LED
- 7- Rotor 1 indicator LED
- 8- Encoder button
- 9- Rotor 2 indicator LED

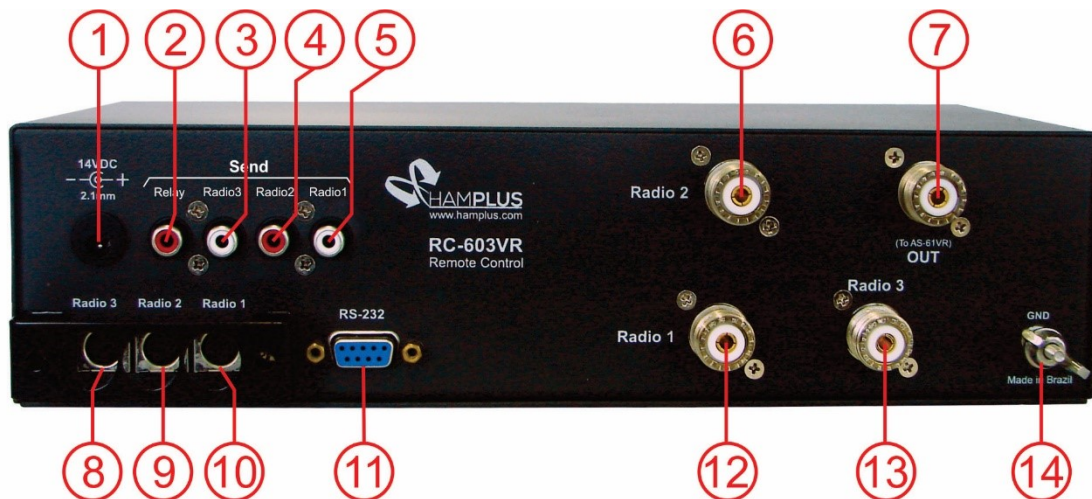

- | | |
|-----------------------------|-------------------------------|
| 1- Auxiliar Power Supply In | 8- Control Cable to Radio 3 |
| 2- Switched Send Relay Out | 9- Control Cable to Radio 2 |
| 3- Send Radio 3 | 10- Control Cable to Radio 1 |
| 4- Send Radio 2 | 11- RS-232 Remote Control Com |
| 5- Send Radio 1 | 12- RF from Radio 1 |
| 6- RF from Radio 2 | 13- RF from Radio 3 |
| 7- RF Out to AS-61VR | 14- GND |

AS-603UR

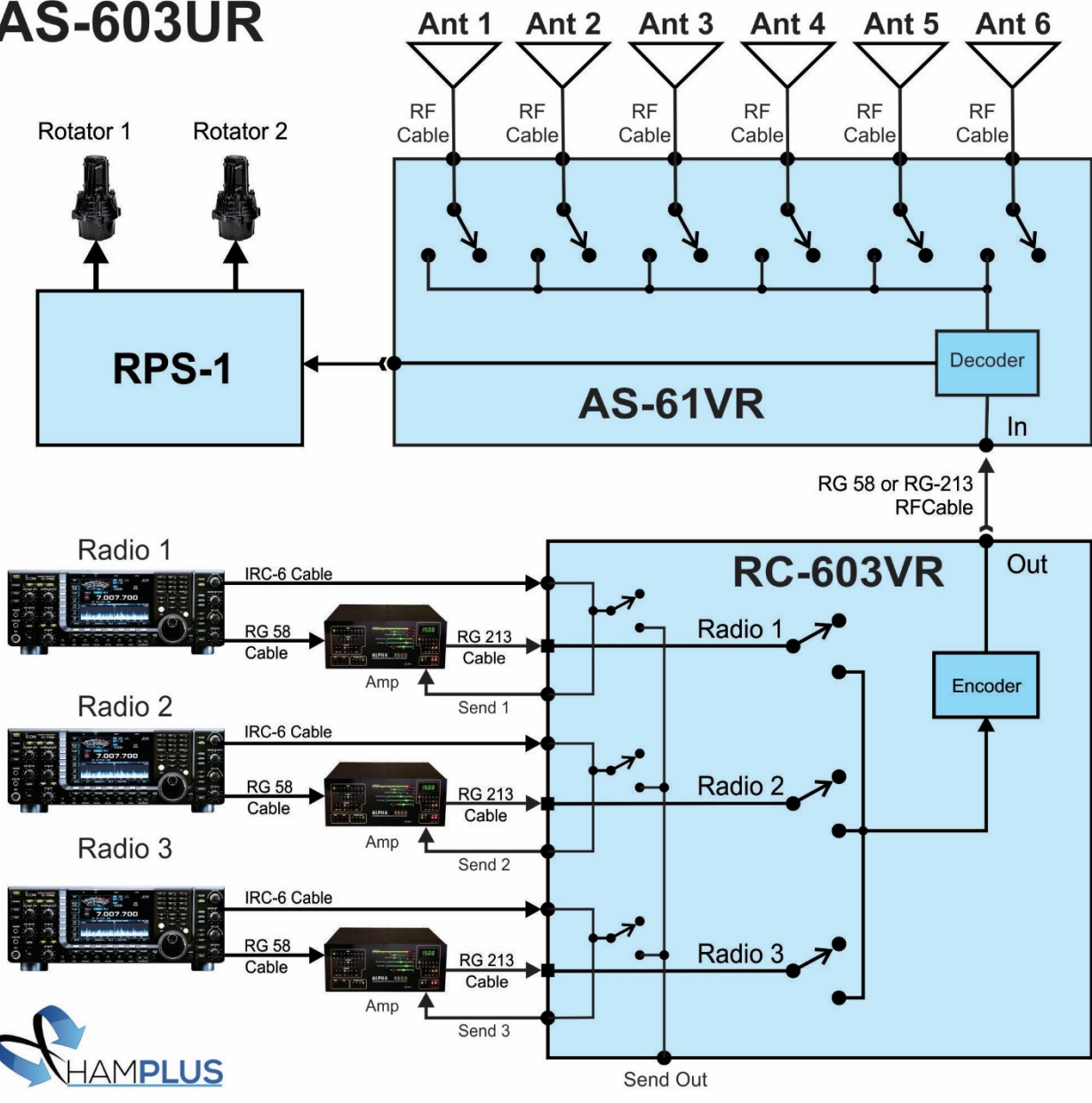

Diagram of blocks and connections of the antenna switch **AS-603UR** without the rotator power supply module, mounted in two cabinets
Cabinet 1 contains the **RC-603VR** controller
Cabinet 2 contains the **AS-61VR** antenna switch

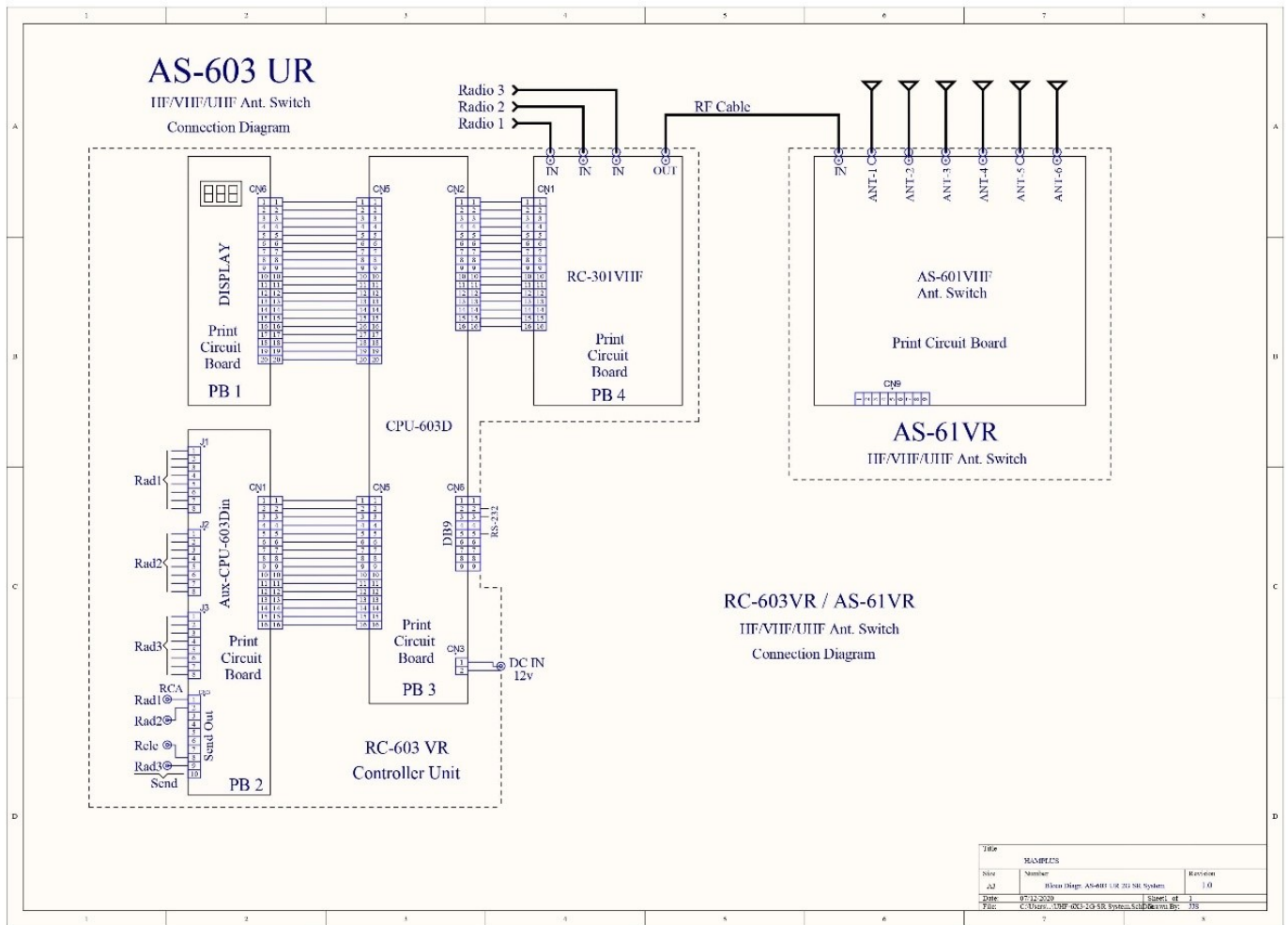

Diagram of the blocks and connections of the antenna switch **AS-603UR** with the rotator power supply module, mounted in three cabinets

Cabinet 1 contains the **RC-603VR** controller

Cabinet 2 contains the **AS-61VR** antenna switch

Cabinet 3 contains the **RPS-1** rotator power supply

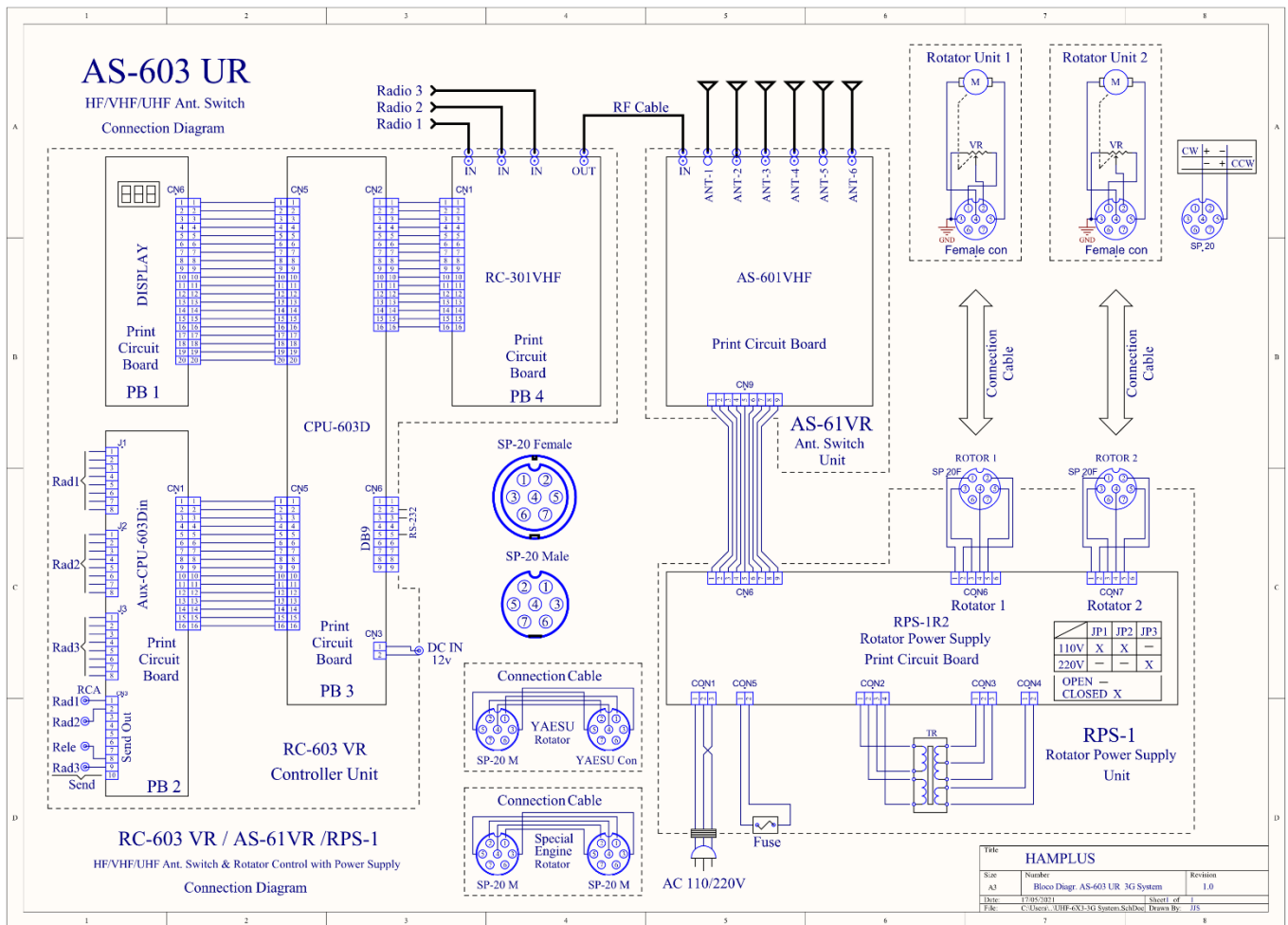
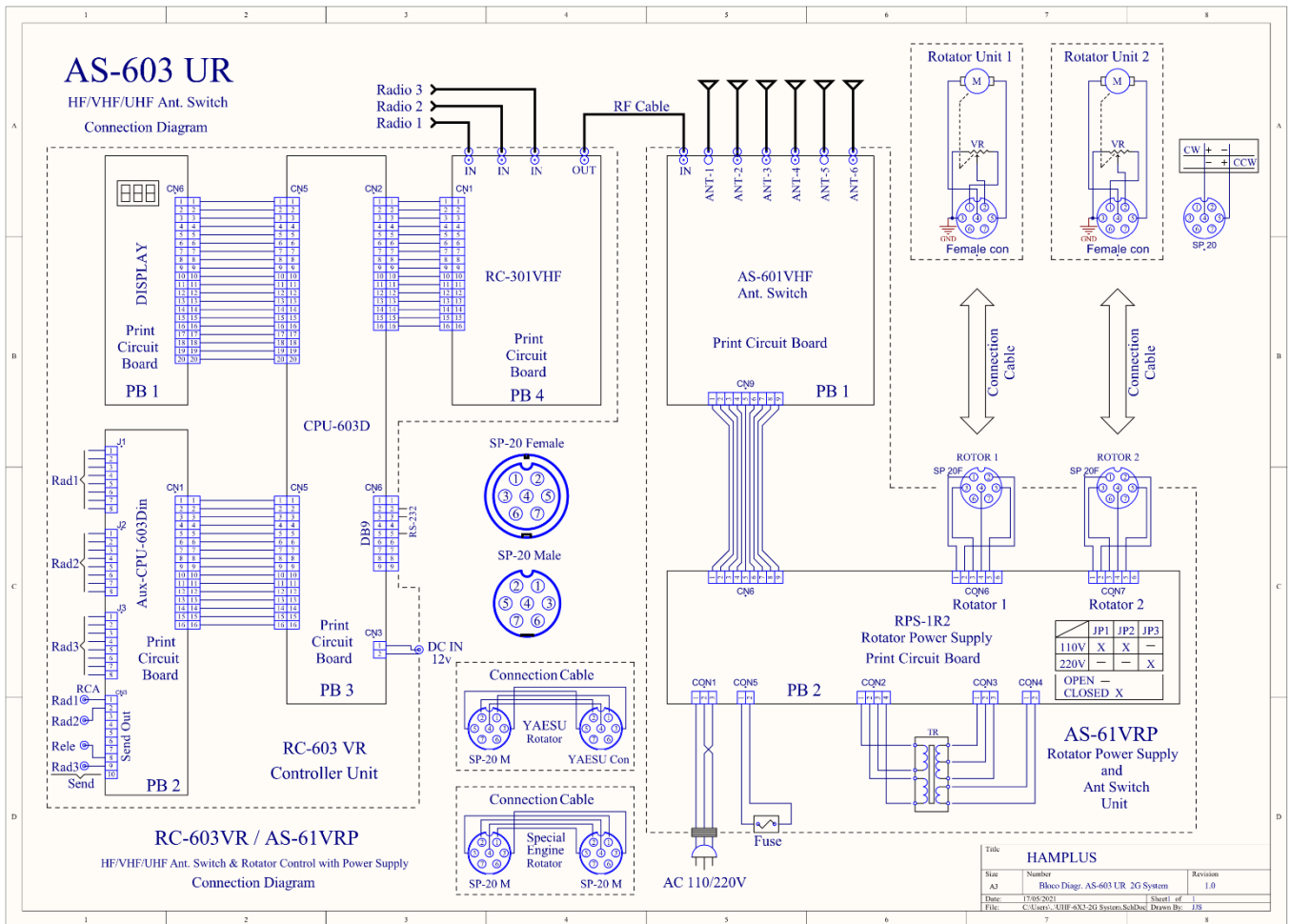
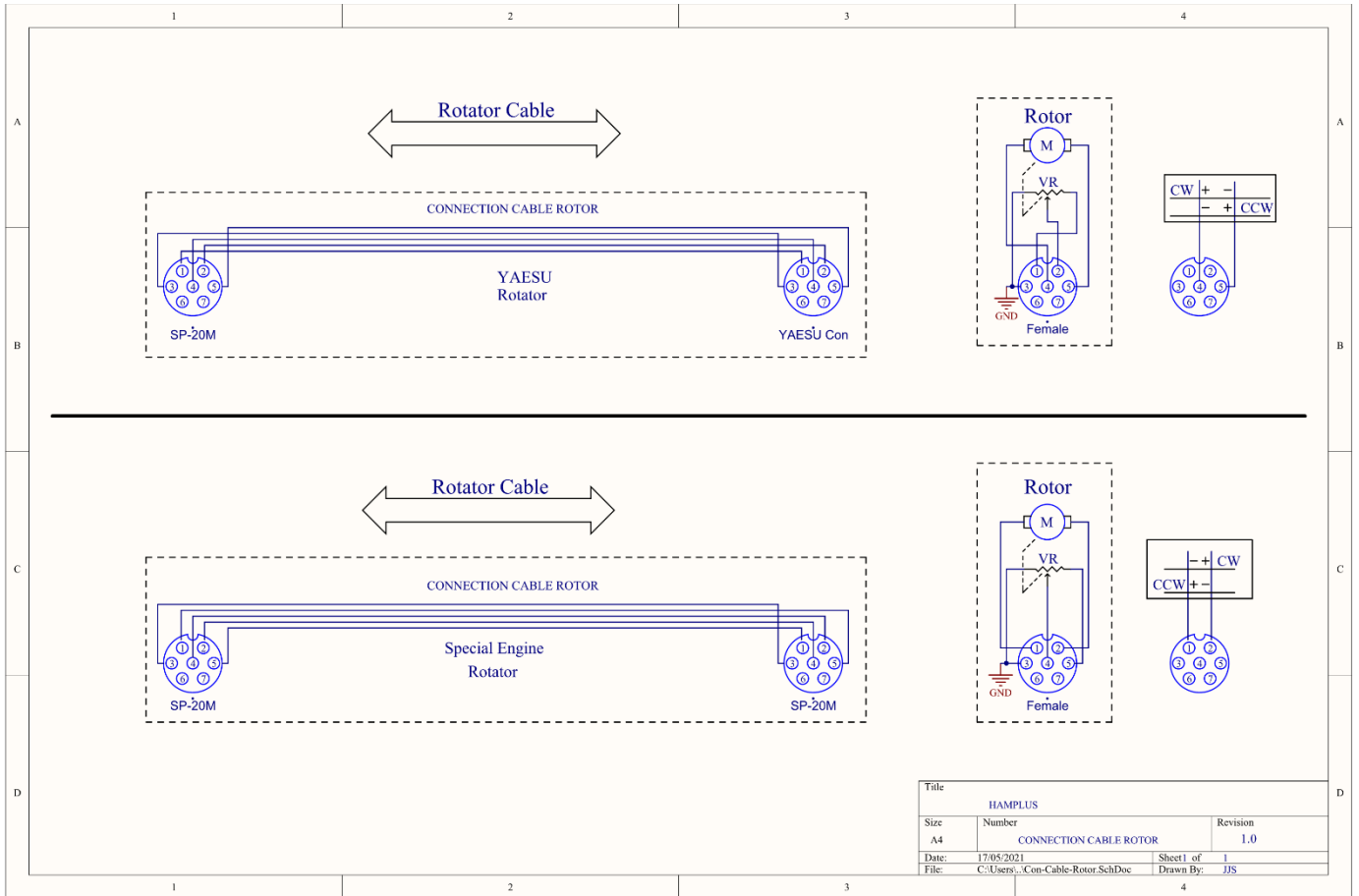

Diagram of blocks and connections of the antenna switch **AS-603UR** with the rotator power supply module, mounted in two cabinets

Cabinet 1 contains the **RC-603VR** controller

Cabinet 2 contains the antenna switch and the rotator power supply **AS-61VRP**





Title			
HAMPLUS			
Size	Number	Revision	
A4	CONNECTION CABLE ROTOR	1.0	
Date:	17/05/2021	Sheet 1 of	1
File:	C:\Users\...Con-Cable-Rotor-SchDoc	Drawn By:	JJS

Labels - print on transparent paper with laser printer

160 m	80 m	40 m	20 m	18 m	17 m	15 m	12 m	10 m	6 m	2 m	70 cm
80 m 40 m	20 m 15 m 10 m	MULTI BAND	LOG	IC 756	IC 7300	IC 7600	IC 7610	IC 7700	FT 897D	FT 1000	WARC
KEN WOOD	KEN WOOD 1	KEN WOOD 2	KEN WOOD 3	K3	K3 1	K3 2	K3 3	YAESU	YAESU 1	YAESU 2	YAESU 3
ICOM	ICOM 1	ICOM 2	ICOM 3	FLEX	FLEX 1	FLEX 2	FLEX 3				

Procedure to place labels on the keys

Push Button Labels



1

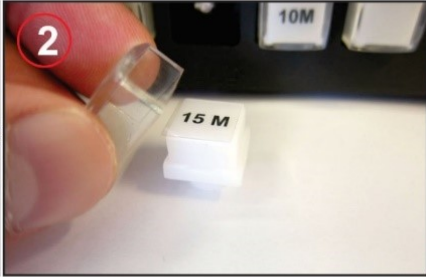

2

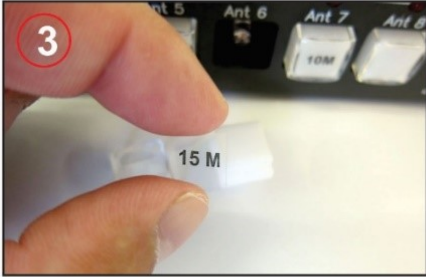

3

HAMPLUS		
Size: A4	Number: Push Button Labels	Rev: 1.0
Date: 25 / 04 / 2019	By: Valmor	
Filename: Labels	Page: 1 / 1	

RC-603VR - IDENTIFICATION PIN



RC-603VR

CONNECTOR MINI DIN 8P



A
B
C
D

HAMPLUS		
Size: A4	Number: Identification Pin	Rev: 1.1
RC-603VR		
Date: 12 / 02 / 2021	By: Valmor	
Filename: RC-603VR	Page: 1 / 1	

RC-603VR / YAESU-FT817 Connection Cable

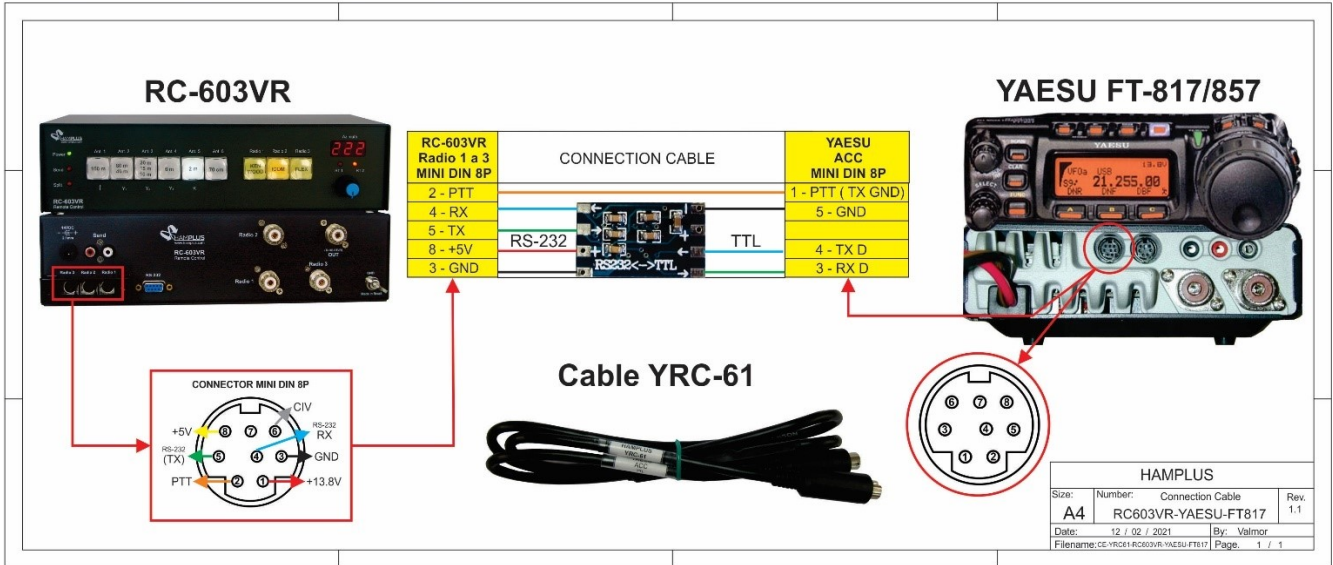

RC-603VR/ YAESU Connection Cable

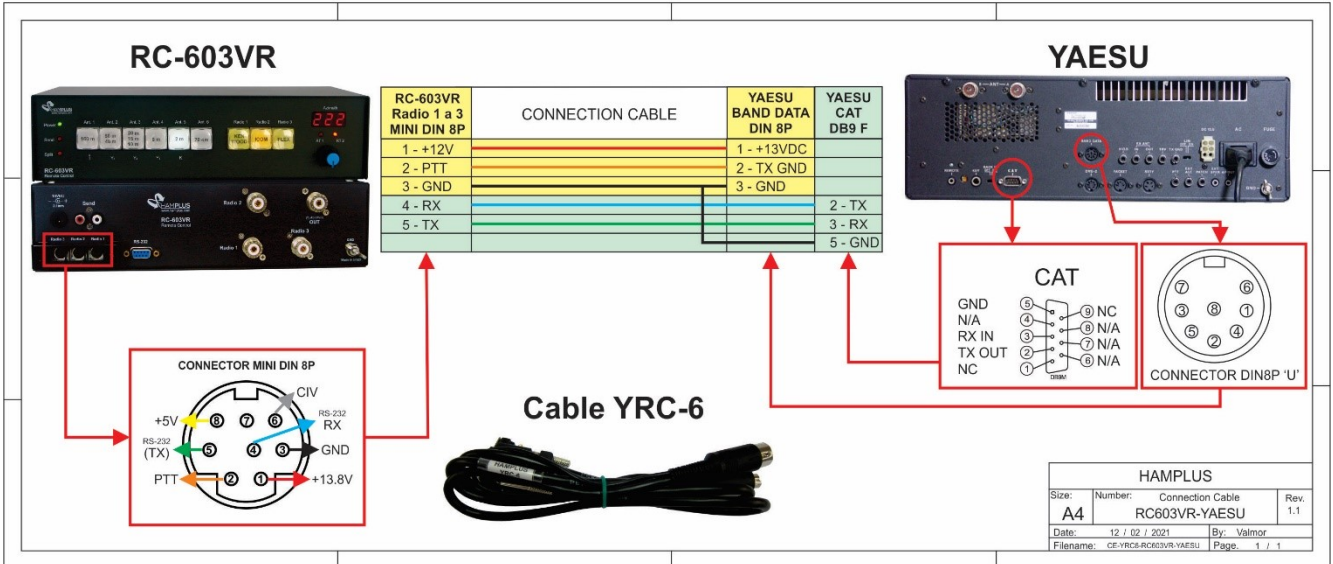

RC-603VR / YAESU Connection Cable

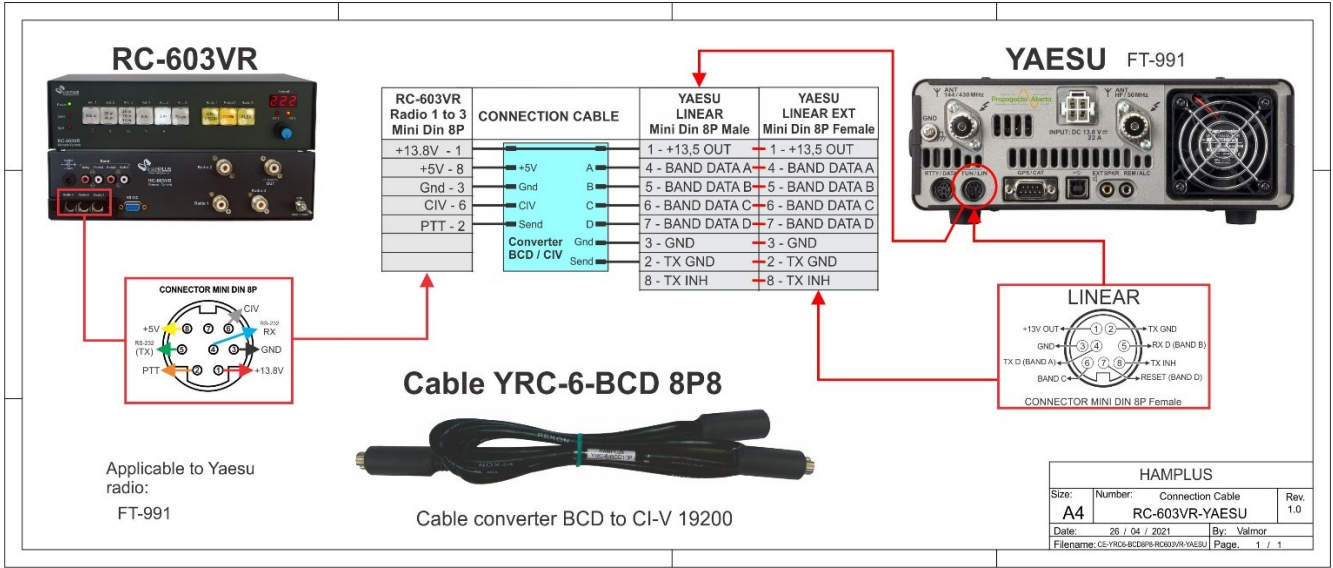

RC-603VR / YAESU Connection Cable

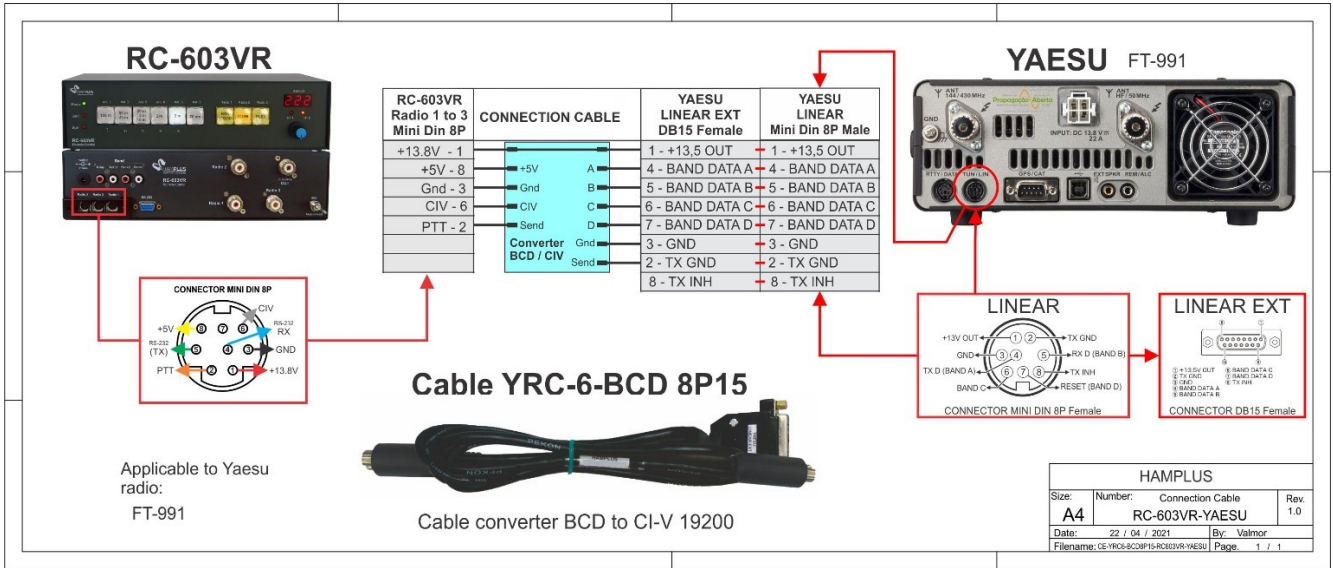

RC-603VR / YAESU Connection Cable

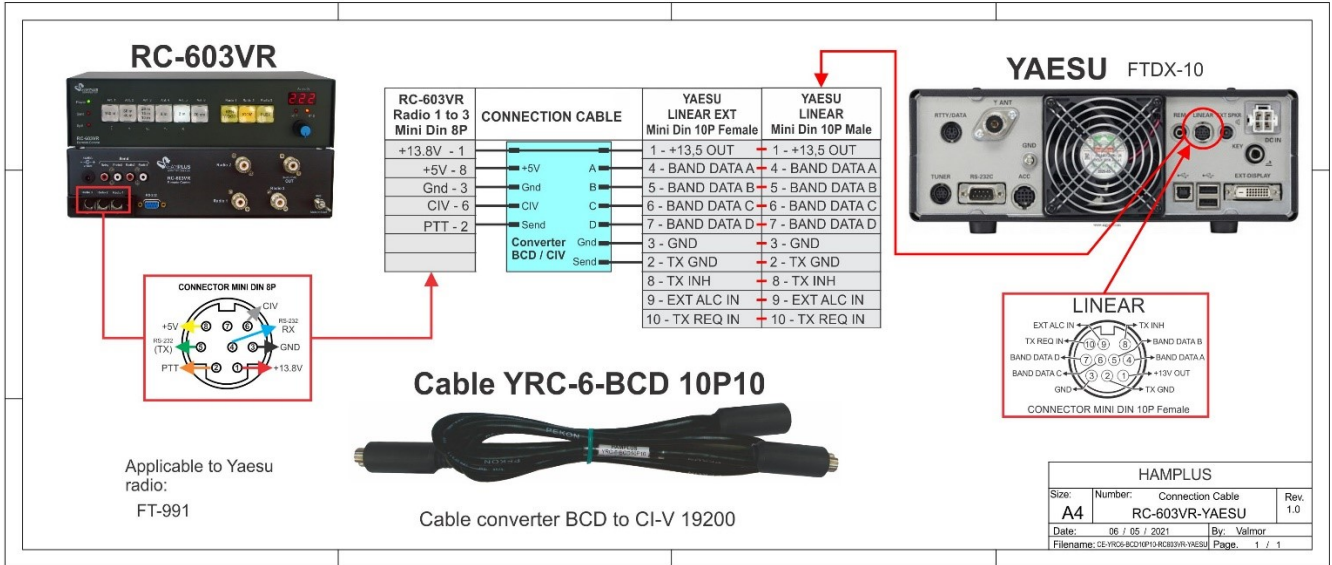

RC-603VR / YAESU Connection Cable

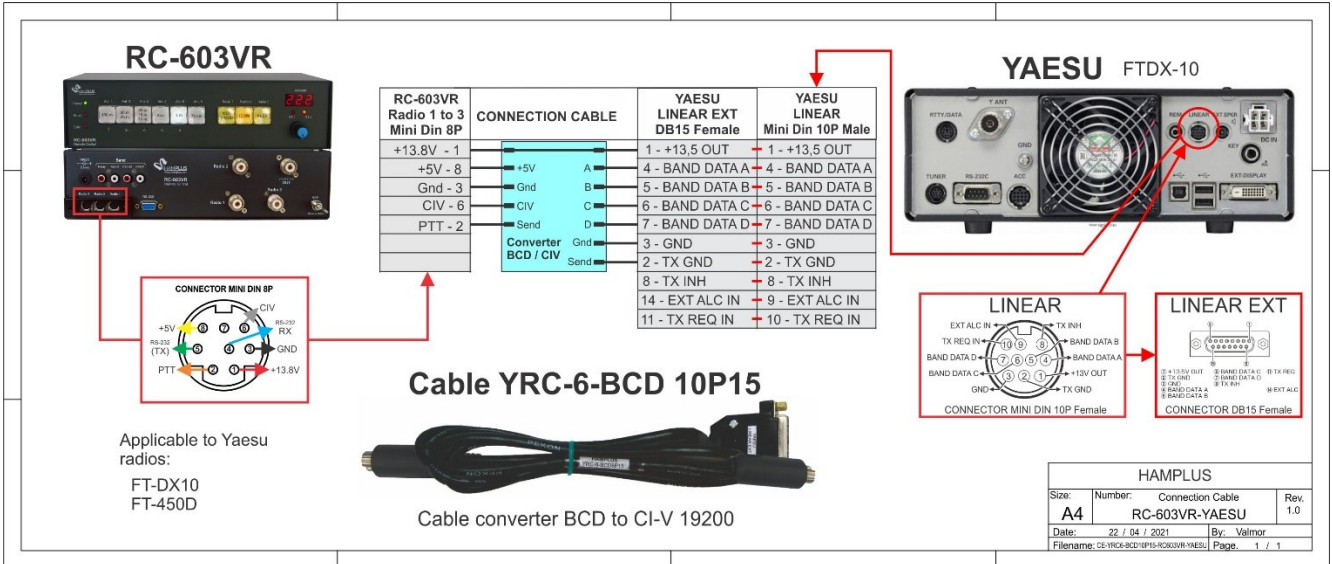

RC-603VR / YAESU Connection Cable

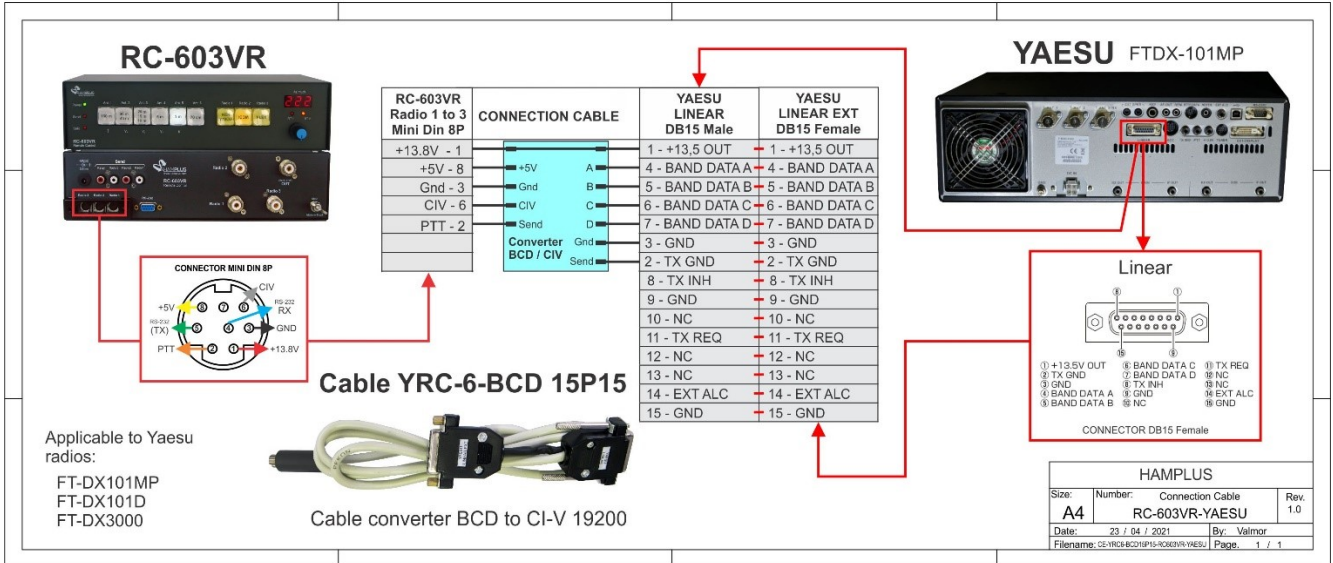

RC-603VR / YAESU-FT450 Connection Cable

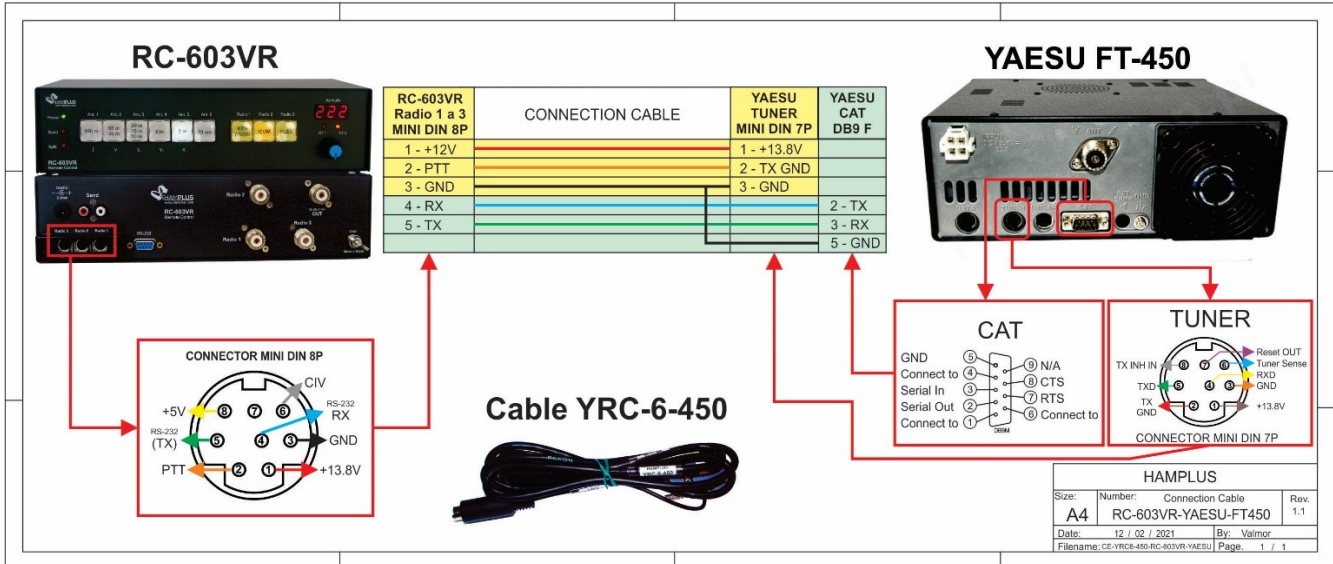

RC-603VR / KENWOOD Connection Cable

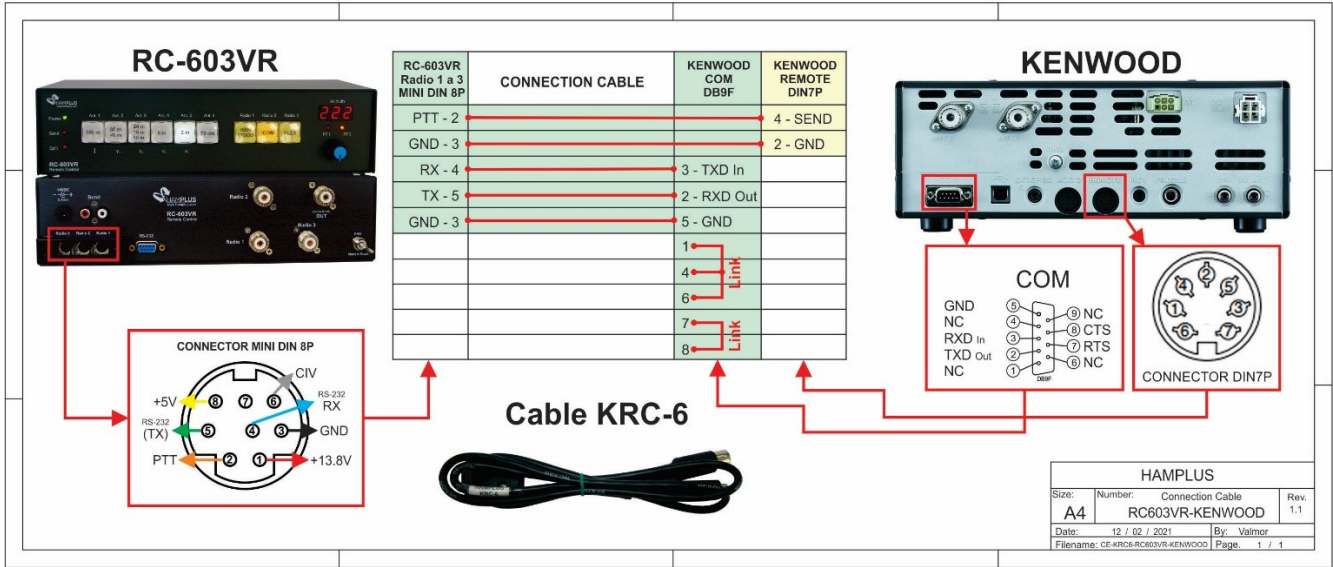

RC-603VR / ICOM Connection Cable

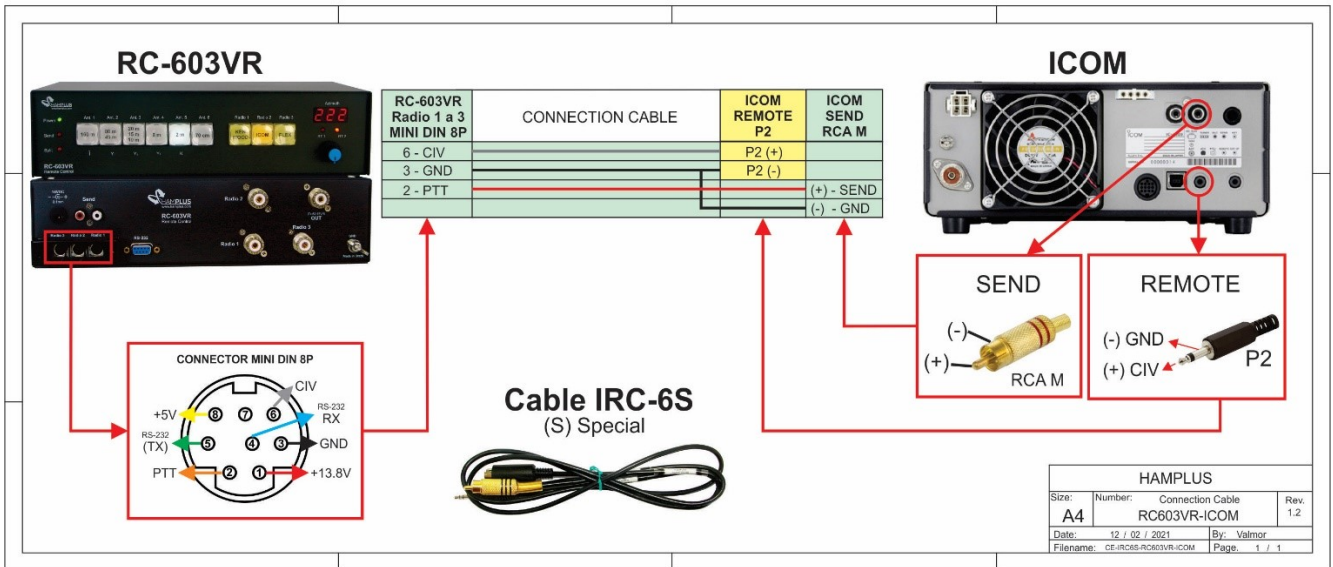

RC-603VR / ICOM Connection Cable

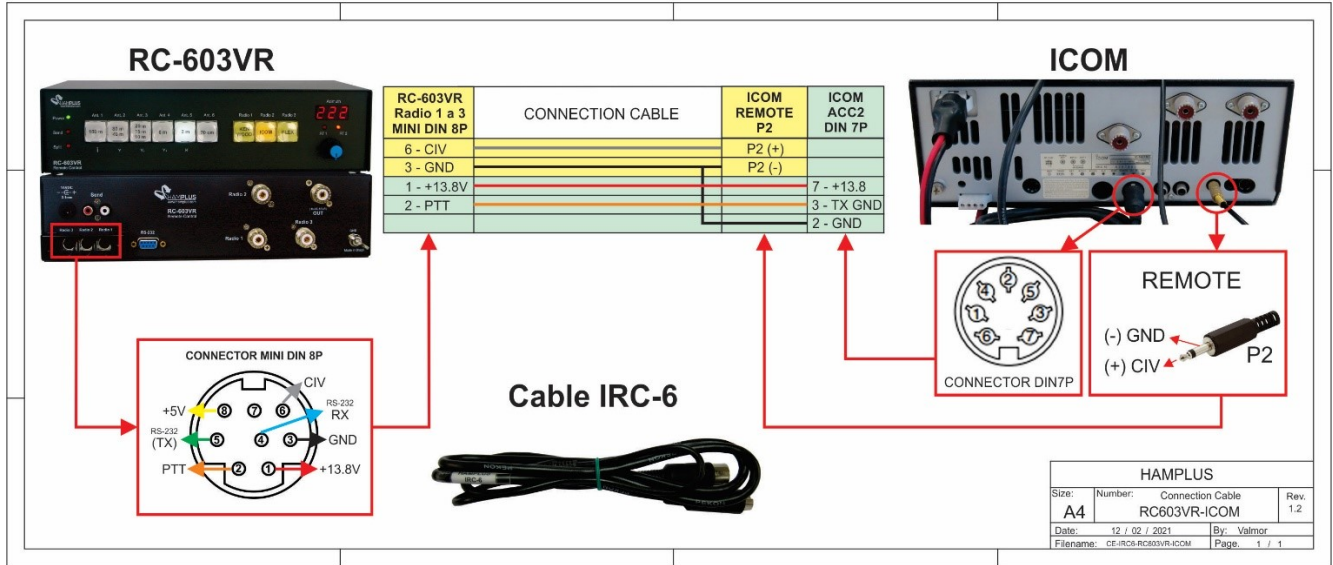

RC-603VR / ICOM Connection Cable

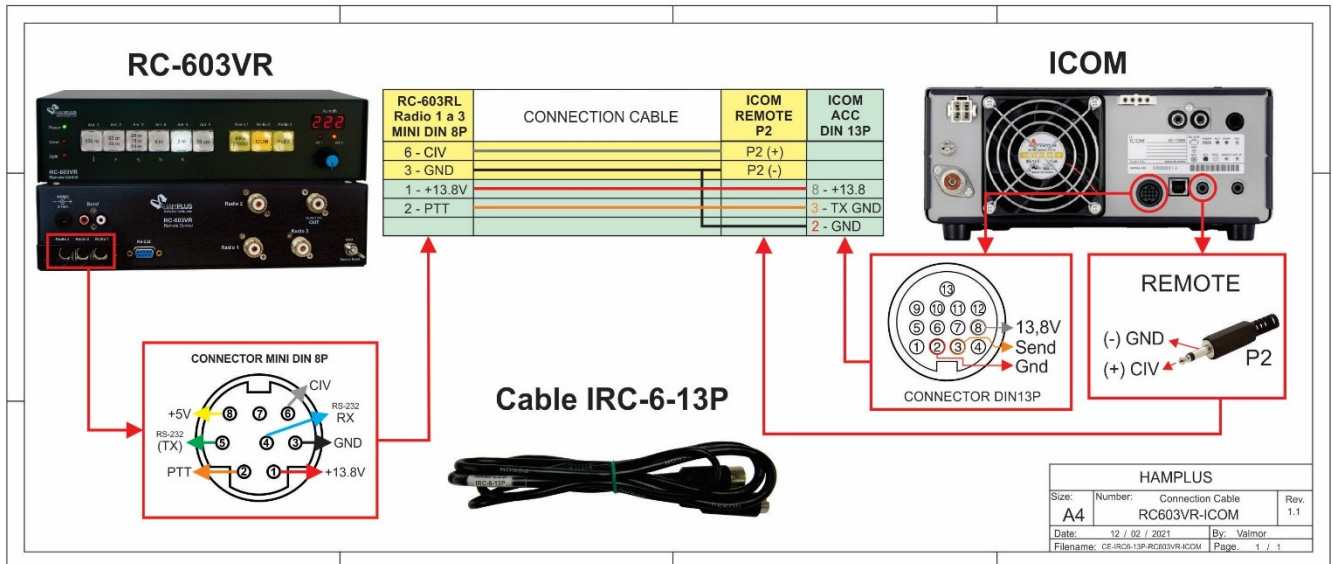

RC-603VR / FLEX Connection Cable

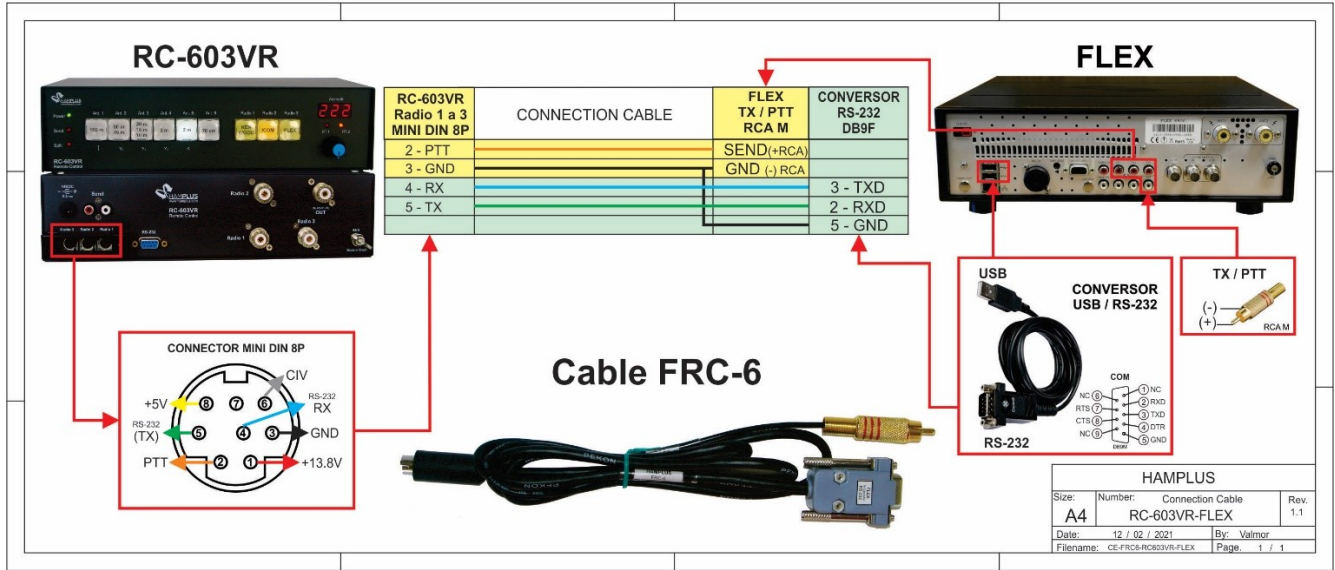

RC-603VR / ELEKRAFT K3 Connection Cable

